

Book I

Night Warrior Handbook

A Guide to Individual Training

for Night Combat

in the Infantry Company

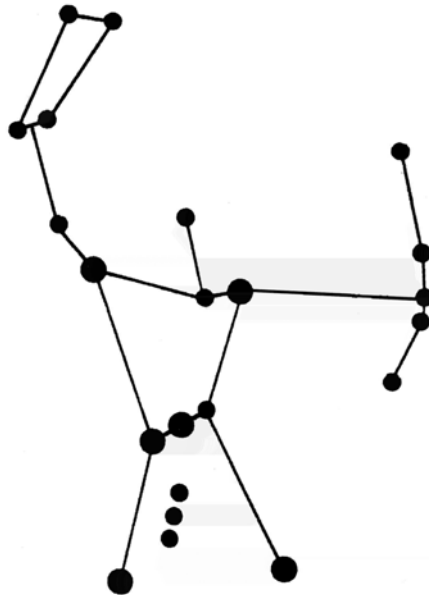

2nd Battalion, 5th Marines

Camp Pendleton, California 92055

1 June 2000

Table of Contents

[Introduction](#)

Purpose and Scope
How to use this Manual

Night Attack on Hill 163
A Draft Concept for Night Operations

[Chapter 1 Night Warrior Individual Training Standards](#)

- Section 1.1** Night Warrior Basic
- Section 1.2** Night Warrior Leader
- Section 1.3** Night Warrior Weapons
- Section 1.4** Additional Night Warrior Standards

Chapter 2 Night Equipment Training for Individuals

- [Section 2.1 Night Vision Goggles](#)
- [Section 2.2 Night Vision Scopes](#)
- [Section 2.3 Weapons Laser Pointers](#)
- [Section 2.4 Hand-held Laser Pointers](#)
- [Section 2.5 Laser Designators](#)
- [Section 2.6 IR Signals](#)
- [Section 2.7 IR Ammunition](#)
- [Section 2.8 Combat ID](#)
- [Section 2.9 Accessories](#)

[Chapter 3 Unaided Night Skills Training for Individuals](#)

- Section 3.1** Unaided Night Weapons Skills
- Section 3.2** Unaided Night Field Skills

[Chapter 4 Night Warrior Training Plans](#)

- Section 4.1** Quarterly Training Plan
- Section 4.2** Night Warrior Field Training Plans
- Section 4.3** ISMT Field Training Plans

Chapter 5 Night Vision Equipment

- [Section 5.1 Night Vision Equipment Distribution Lists](#)
- [Section 5.2 Batteries](#)
- [Section 5.3 Standard Armory Procedures](#)
- [Section 5.4 Acquiring Equipment](#)

Night Warrior Handbook Contributing Editors:

Capt Fidel Arroyo
Lt Stefan Barr
Capt Andrew "Kingpin" Butler
Marine Gunner Dwight Frazer
Capt Douglas "KD" Lang
Capt Garret Means

**SSgt Clifford Meyer
Lt Aaron Puttroff
Lt Patrick Rapicault
Capt Tye Wallace**

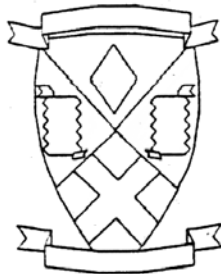

If you have any ideas on how to improve this publication, please contact:

Major B.B. McBreen
2nd Battalion, 5th Marines
Camp Pendleton, California 92055
(760) 763-0867

abmcbreen@aol.com

Purpose and Scope

Purpose

The *Night Warrior Handbook* is a training guide designed to help train an infantry company in the *individual* skills needed to conduct a night attack.

The *Night Warrior Handbook* is Book I of a three-book series:

Book I: **Night Warrior Handbook** is a training guide designed to help train an infantry company in the *individual* skills needed to conduct a night attack. Book I includes individual training standards (ITS), equipment training handouts, training plans, and night equipment guidelines.

Book II: **Night Combat for Infantry Companies** is a training guide designed to help train an infantry company in the *collective* skills needed to conduct a night attack. Book II includes SOP battle drills for squads, platoons, and weapons sections, training plans, and techniques for integrating supporting units into night operations.

Book III: **Night Combat Guidebook for Infantry Leaders** provides tools and materials to educate infantry leaders on the challenges of fighting at night. Book III includes night mission planning, the physiological and human factors of night fighting, laser, thermal, and night vision technical information, safety, and a bibliography.

The *Night Warrior Handbook* is a training reference for all infantry leaders. It is not prescriptive. Sections on training and individual training standards can be used by leaders in any order and for any purpose required. Most of the training standards and techniques, although presented in the context of an infantry company night attack, can be used during any types of operations.

Scope

The *Night Warrior Handbook* was designed to support Marine infantry company night operations. No combat support, combat service support, or aviation-specific operations are covered. Although most material is relevant to any forces conducting operations at night, no attempt has been made to cover drivers, communicators, medical personnel, mechanics or any of the other hundreds of skilled Marines who need training to operate at night.

How to use this Manual

Organization

Chapter 1 contains individual training standards (ITSs) for night fighting skills, organized to cover basic, leader, and weapons section tasks. A fourth section contains optional tasks that leaders can select for specific equipment or missions. These draft ITSs have yet to be incorporated in MCO 1510.35C *Individual Standards for Infantry*.

Chapter 2 contains equipment training materials. For each piece of equipment, there is a data sheet, a training handout intended to be xeroxed by NCOs for instructional use, and a section on tactics, techniques and procedures. Chapter 3 contains tactics, techniques and procedures for unaided night fighting skills.

Chapter 4 includes sample field training plans. Each plan references the standards in Chapter 1 and the guidance in Chapters 2 and 3. Chapter 5 contains recommended equipment SOPs.

Recommended Quick Start Instructions

1. Assign all equipment to individual Marines. Use NAVMC 10520 cards for each piece of equipment. See Chapter 5.
2. Qualify all Marines on the Night Warrior Basic Qualification. See Chapter 1 for ITSs, Chapter 2 for equipment training guidelines, Chapter 3 for unaided techniques training guidelines, and Chapter 4 for a sample field training plan.
3. Qualify selected Marines on the Night Warrior Leader Qualification. See Chapter 1 for ITSs, Chapter 2 for equipment training guidelines, Chapter 3 for unaided techniques training guidelines, and Chapter 4 for a sample field training plan.
4. Qualify specific Marines on selected Night Warrior Weapons tasks and any additional tasks. See Chapter 1, Sections 1.3 and 1.4 for ITSs, and Chapter 4 for a sample field training plan.
5. When the individual training phase is complete, move on to collective training. See Book II: *Night Combat for Infantry Companies*.
6. Throughout the training cycle, educate unit leaders on combat at night. See Book III: *Night Combat Guidebook for Infantry Leaders*.

Night Attack on Hill 163

In the cool darkness, the radio squawked. "Roger Four-One. This is Kingpin. I've got you with three dots and a dash. I've also got Three-Zero on the deck with seven dots. Stand by to snake your target."

Sergeant Martin heard the whop-whop of the lead Cobra, callsign "Kingpin," off behind his left shoulder, but he didn't turn to look. "Kingpin. Four-One. Snaking NOW."

At his feet, there was a slight rustle as each of his six teams adjusted its machinegun on the dancing IR spot 900 meters away.

"Four-One, this is Kingpin. I see your snake seven hundred meters northeast of your firefly."

In the next instant, the night was torn apart by far more noise, tracers, and detonations than Martin had expected. In a head-shaking instant, Martin realized what he was watching. Large green thumping tracers arced up toward the Cobras.

"New Target! New Target!" he yelled to his gunners. "Fire on my spot!" But the machinegunners did not need the spot. The origin of the enemy tracers was clearly visible with or without goggles. The gunners shifted west and opened up, adding to the crescendo. An hour ago, Martin had squatted with each gun and ran the Support-by-Fire drill. Friendlies were at 312 degrees, obliging him by marking their position with a blinking Phoenix beacon inside an M-203 tube. Now Martin was glad he had been meticulous. "Watch your left limit!"

"Three-Zero this is Four-One! I have an enemy machinegun, with at least four men, firing at the Cobras. Location is three-hundred meters southwest of objective eleven!"

"Roger Four-One..."

"Break, Break! Four-One, this is Six." The company commander was in the draw with 3rd Platoon. "Cease fire on that target. Plan still stands. Open fire on Objective one-one with tracers, NOW! Three-Zero. Move NOW!"

"Four-One. Roger, over."

"Three-Zero. Roger, moving now."

Martin flipped up his goggles, knelt down, and barked at his gunners. "Targets one and two on the objective, with tracers..."

"I see them moving!" an A-gunner shouted.

"Hurry up!" Off in the darkness, nothing was visible. Martin flipped down his goggles and immediately caught the seven-dot blink of 3rd Platoon's Phoenix. That would be the right flank. The left flank, he knew, was marked with an IR chemlite, but he couldn't see it.

His machinegunners opened up, this time with tracers, on their original targets. Enemy small arms fire now cracked back at them. Third Platoon was moving out there, urgently, but quietly, and completely blacked out. The enemy had not yet seen them. Martin saw an IR light beam from 3rd Platoon arc left to right and then rest steadily on some unseen target. "Too strong for a PAQ-4," he thought, "must be a hand-held." He watched a dozen thin PAQ-4 or PEQ-2 weapons beams converge on the brighter beam.

"Crack!...BOOM!" The sound of a rocket and its near-immediate impact was followed by the sudden roar of automatic weapons. Third Platoon was going in!

The Cobras came back, well to the north this time, guided by Bunny, the company FAC. "Kingpin, this is Bunny. I'm on the deck with the lead element. Do you see my rope?" Bunny was making circles in the sky with a hand-held laser pointer.

"Bunny. Kingpin. I see you and I see your helmets. Two groups. One with you and one further north." The one-inch square of glint tape on each Marine's helmet was visible inside the cockpit. Both 1st and 3rd Platoons were now inside the enemy position.

"Roger, Kingpin. Our thermals picked up and then lost two vehicles moving east, probably on the road toward checkpoint Five-Eight-Tango. We have no friendlies that far east, over."

"Roger, Bunny. On the way."

The company had overrun Objective 11 with lots of short-range, well-aimed fire but no grenades, no mortars, and no illumination. The Marines quickly established new positions, consolidated units, and redistributed ammunition. On the commander's guidance, Two-Three laid out an IR "T" to mark an LZ on the southern slope, signaled the Medevac birds with a chemlite buzzsaw, and then carried eleven casualties to the birds. The attack had taken nineteen hours to prepare, but only thirty-five minutes to execute.

Nine hundred meters away, while his gunners and the mortarmen broke down their equipment, Sgt Martin gazed north toward Hill 163 and smiled. "That's the reason we train so hard," he thought. To the unaided eye, and especially any remaining enemy observers, the hill was still blacked out. During the entire action, from the reconnaissance, infiltration, support-by-fire, and assault, to the consolidation and pursuit by fire, to the treatment and evacuation of casualties by air, every task had been done in complete darkness.

A Draft Concept for Night Operations

A 21st Century Warfighting Concept

This concept describes the future operating capabilities needed by expeditionary MAGTFs to fight at night against a sophisticated opponent.

Introduction

In this century, during both world wars, Korea, Vietnam, and hundreds of other actions, the Marine Corps has fought at night. The corporate memory and lessons learned from these actions are contained in our warfighting manuals. Technology, while improving many of our night fighting capabilities, does not erase these costly lessons. Future night fighting capabilities need to be developed from historical experience, new technology, and experimentation in training.

Concept Linkage

From *National Security Strategy for a New Century* to *Joint Vision 2010*, *From the Sea, Forward...from the Sea* and *Operational Maneuver From the Sea (OMFTS)*, the Marine Corps has defined a direction for future doctrinal developments. *MCDP-1 Warfighting* defines our warfighting doctrine. The Marine Corps Master Plan includes Required Operational Capability number 16 as "The capability to operate effectively at night, in all weather, and on an obscured battlefield." All of the tactical night fighting issues discussed in this concept paper support these baseline doctrinal concepts.

Purpose and Scope

The purpose of this concept is to define the desired night fighting capabilities of the Marine Corps and thereby set the incremental goals necessary to reach these capabilities.

The scope of this concept is total. Although only our operating forces, MAGTFs consisting of aviation, ground, and service support elements engage the enemy, our training, education, procurement, and other supporting activities exist to support and field these operating forces.

Anticipated Threats

The Marine Corps, as the nation's expeditionary force in readiness, must plan for threats in all parts of the globe, in all types and levels of conflict. Given the availability of night fighting technology, all threats must be assumed to have night vision capability.

During the next fifteen to twenty years, we can expect threat forces to develop new night fighting capabilities as well as counter measures to U.S. night fighting technology. These capabilities can include, but are not limited to:

- Same generation night vision devices through black market and U.S. forces
- Countermeasures for thermal sights
- Tactics to minimize U.S. night vision superiority
- Choosing terrain that minimizes U.S. night vision superiority such as MOUT

Night Fighting Capabilities

The Marine Corps has tremendous night fighting potential. This potential is the sum of our technology, support, logistic backing, skilled leadership and high quality Marines. A lack of training focus however, makes our current night fighting capability far less than our potential suggests. We cannot mistake *potential* capability for *actual* capability.

Future Operations

Our warfighting doctrine demands that we capitalize on our strengths and exploit enemy vulnerabilities. Future operations will use darkness and the Marine Corps' expertise in night operations to overwhelm the enemy's ability to respond and decisively defeat his forces.

Night Fighting Scenarios

Every standard Marine Corps operation can be executed at night. Future combat scenarios, from landing operations, assault support operations, close air support operations, infantry combat operations, MOUT operations, MOOTW operations, and others, need to be fully defined as completely executable at night. These scenarios will then guide night fighting development.

Future Operational Capabilities

Goals. The Marine Corps will fight primarily at night.

- Darkness will NOT reduce our ability to fight. The MAGTF must be able to operate with the same capability twenty-four hours a day. The MAGTF must be able to operate all units and all platforms in complete darkness. All communications, all logistics, all movement, and all combat techniques will be optimized for night operations.
- The MAGTF will operate completely within the IR spectrum. All signals, all optics, and all weapons will have IR capability. Leaders, pilots, gunners, communicators, equipment operators, and all ground combat forces, especially all infantry Marines, need IR vision.
- The MAGTF will operate on a common night vision wavelength band. All night vision will see the same picture. Thermal vision will *augment*, not replace, night vision goggles.
- Our standard offensive capability will be the night attack. The primacy of night operations is defined by our ability to attack at night. Supporting arms, assault support, CAS, and other units will optimize their night techniques to support the GCE during the night attack.
- The MAGTF will operate with a common night target identification system. This applies at the

MAGTF level, where helicopters communicate target information with ground forces. This applies at the squad level, where all Marines communicate to identify the same target. All weapons need laser pointers to mark targets. Scopes, thermal or electro-optical, are additional equipment.

- The Marine Corps will be the most well-trained night fighting force in the world.

Constraints. We must realize that the biggest constraint on night operations is NOT technology, but the limitations of the individual Marine. Leaders must be educated on the physiological limits of their Marines. The secondary night constraints imposed by technology, training, and maintenance need to be clearly identified and well-understood by battlefield leaders.

Infrastructure. No modification to our primary infrastructure is required to meet these goals. Some ranges and training facilities will be updated to better suit night training.

Doctrine. Our warfighting doctrine encourages night fighting as a technique that attacks enemy weakness. A series of night fighting manuals needs to be developed and annually updated to reflect lessons learned and share the impacts of rapidly changing night vision technology.

Organization. Current MAGTF organization supports these night fighting goals.

Training and Education. Training, not equipment, is the key component to night fighting capability. Manuals, training standards, schools, ranges, and facilities need to be *significantly* enhanced in order to support this night fighting concept. Today's training model will not suffice.

CAX needs to be changed. The MCCRES needs to be changed. The T&R manuals need to be changed. MEU(SOC) standards need to be changed. Individual Training Standards need to be changed. Large exercises, which drive unit preparation training, need to focus on night fighting.

Support. Current Marine Corps support structure does not need to be modified.

Material. Current Marine Corps material support does not need to be modified.

Technology Research and Development

Research and development is guided by Marine Corps warfighting goals. Development and acquisition of night equipment will support our warfighting doctrine and night fighting concept. The "Revised" Aided Battlefield Vision Implementation Plan (ABVIP) and the Night Vision Equipment Distribution Plan reflect current technology direction and distribution.

Recommendations

MCCDC should appoint a general officer night fighting advocate to serve as a lightning rod for MAGTF night fighting development. A five-year night fighting plan should be implemented. An annual night fighting conference should present results of experimentation, technical and tactical developments, and new doctrinal and training products. To reach our goal, each and every Marine should be challenged to contribute to the improvement of our night fighting capability.

Chapter 1

Night Warrior Individual Training Standards

Section 1.1

Qualification Standards for Night Warrior Basic

The following Individual Training Standards (ITS) define the Night Warrior Basic (NWB) Qualification. These are the minimum skills needed by all hands before unit-level training begins. All infantry Marines, including Corpsmen, are expected to be NWB qualified. Existing ITSs from MCO 1510.35C *Individual Training Standards for Infantry* are referenced.

1. Operate PAQ-4C (or PEQ-2A) on M-16A2 (or M-203) (or M-249)
2. Operate PVS-7B (or -7D)
3. Operate PVS-14
4. Engage targets at night with M-16A2 (or M-203), PVS-7 (or PVS-14), and PAQ-4C (or PEQ-2A)
5. Engage targets at night with the M-249, PVS-7 (or PVS-14), and PAQ-4C (or PEQ-2A)
6. Camouflage self and equipment
7. Silence weapon and equipment
8. Operate silently at night
9. Execute an individual night infiltration

1. TASK: Operate PAQ-4C (or PEQ-2A) on M-16A2 (or M-203) (or M-249)

CONDITIONS: In the dark. With an M-16A2 modified with the proper PAQ-4C mount. With a PAQ-4C that is already

boresighted to the weapon. With the PAQ-4C not mounted to the weapon. Without NVGs.

STANDARD: The Marine must execute the following tasks within (2) minutes:

- a. Remove old batteries. Insert new batteries.
- b. Mount the PAQ-4C to the weapon.
- c. Activate the PAQ-4C beam. De-activate the PAQ-4C beam.

NOTES:

- a. Either PAQ-4C or PEQ-2A can be mounted to M-16A2, M-203 or M-249.
- b. The Marine Corps has PAQ-4C mounts for M-16A2 and M-203, but has not yet acquired PAQ-4C mounts for the M-249, so Marines must use expedient methods for mounting.
- c. Boresighting PAQ-4C is a leader task. See Section 1.2 **Night Warrior Leader**.
- d. MCO 1510.35C task *0300.2.5 Maintain AN/PAQ-4B IAL* applies only to the '-B' model, which the Marine Corps never acquired.
- e. The PEQ-2A, an upgrade of the PAQ-4C, will be fielded in 2001.

REFERENCE: TM 09596C-12&P/1A *PAQ-4C Infrared Aiming Light*

2. TASK: **Operate PVS-7B (or -7D)**

CONDITIONS: In the dark. With a PVS-7B or -7D.

STANDARD: The Marine must execute the following tasks:

- a. Remove old batteries. Insert new batteries.
- b. Remove lens cover. Attach sacrificial window.
- c. Don and adjust headmount OR Attach helmet mount to helmet. Attach PVS-7 to mount.
- d. Turn PVS-7 on.
- e. Execute the four-step focus process: focus main lens, focus each eyepiece diopter, adjust interpupillary distance, adjust eye relief.
- f. Identify detailed object at 20m.
- g. Turn IR illuminator on and off.
- h. State the meaning of the red dot indicator in the left eye.
- i. State the meaning of the red dot indicator in the right eye.
- j. Flip PVS-7 to 'up' position on helmet mount OR Remove PVS-7 from head mount.

REFERENCE: TM 09500A-10/1A *PVS-7 Night Vision Goggles*

3. TASK: **Operate PVS-14**

CONDITIONS: In the dark. With a PVS-14.

STANDARD: The Marine must execute the following tasks:

- a. Remove old batteries. Insert new batteries.
- b. Remove lens cover. Attach sacrificial window.
- c. Don and adjust headmount OR Attach helmet mount to helmet OR Attach small arms mount to weapon. Attach PVS-14 to mount.
- d. Turn PVS-14 on.
- e. Execute three-step focus process: Adjust eye-relief, focus objective lens, focus eyepiece diopter. Identify detailed object at 20m.
- f. Turn IR illuminator on and off.
- g. Adjust variable gain.
- h. Attach compass. State bearing to designated landmark.
- i. Attach 3X magnifier lens.
- j. State the meaning of the flashing red dot indicator.
- k. State the meaning of the constant red dot indicator.
- l. Flip PVS-14 to 'up' position on helmet mount OR Remove PVS-14 from headmount OR Remove PVS-14 from weapon.

REFERENCE: TM 10271A-10 *AN/PVS-14*

4. TASK: **Engage targets at night with M-16A2 (or M-203), PVS-7 (or PVS-14), and PAQ-4C (or PEQ-2A)**

CONDITIONS: In the dark. With an M-16A2 modified with the proper PAQ-4C mount. The PAQ-4C is mounted and boresighted. The PVS-7 (or PVS-14) are mounted to the headmount or helmet mount, and are adjusted and focused. The weapon is loaded with 20 rounds. The Marine is wearing a helmet, flak and deuce gear. The targets are 100 meters downrange. A 5-second window is allowed for each shot. (10) rounds are fired prone, (5) kneeling, and (5) offhand.

STANDARD: The Marine must hit the targets with 14 of 20 rounds (70%).

NOTES:

- a. Helmet, flak and deuce gear is worn to simulate night attack equipment.

- b. Either PAQ-4C or PEQ-2A can be mounted to either M-16A2 or M-203.
- c. MCO 1510.35C task *311.1.2 Engage Targets with the M-16A2 During a Night Attack* sets a 70% standard for Marines without NVGs.
- d. MCO 1510.35C task *0311.3.5 Engage Targets with the M-203 during a Night Attack* applies to the grenade launcher fired without NVGs.
- e. MCO 1510.35C task *0300.2.7 Engage Targets with the M-16A2 using the AN/PAQ-4B IAL* applies only to the ‘-B’ model, which the Marine Corps never acquired.

5. TASK: Engage targets at night with the M-249, PVS-7 (or PVS-14), and PAQ-4C (or PEQ-2A)

CONDITIONS: The PAQ-4C is mounted and boresighted to the M249. The PVS-7 (or PVS-14) are mounted to either the head mount or the helmet mount, and are adjusted and focused. The weapon is loaded with (100) rounds. The Marine is wearing helmet, flak and deuce gear. Five targets are 100m downrange.

STANDARD: The Marine must hit each target.

NOTES:

- a. The Marine Corps has PAQ-4C mounts for M-16A2 and M-203, but has not yet acquired PAQ-4C mounts for the M-249, so Marines must use expedient methods for mounting.
- b. The PEQ-2A, an upgrade of the PAQ-4C, will be fielded in 2001.
- c. MCO 1510.35C task *0311.2.8 Engage Targets with the M-249 During a Night Attack* sets a 70% standard for Marines without NVGs.
- d. This standard applies only to Marines assigned as Automatic Riflemen.

REFERENCES:

- a. FM 23-14 *Squad Automatic Weapon, M-249*
- b. TM 08611A-10/1 *Operator's Manual, Machinegun, 5.56mm, M-249*

6. TASK: Camouflage self and equipment

CONDITIONS: Wearing combat equipment and weapon without pack. In daylight. With the following equipment available: cammie paint, local vegetation, burlap, or old utilities.

STANDARD: The Marine must meet the following standards:

- a. No skin showing.
- b. Helmet outline broken up.
- c. Vegetation used as natural camouflage.

d. Marine difficult to observe against background vegetation at 100m.

7. TASK: Silence weapon and equipment

CONDITIONS: With combat equipment, pack and weapon. In daylight. With cloth tape.

STANDARD: The Marine must silence his equipment so that he can remove pack, jump up and down, and hit the dirt without being heard by a listener at 20m.

8. TASK: Operate silently at night

CONDITIONS: Wearing helmet, flak, deuce gear, pack and weapon. In the dark. Without NVGs.

STANDARD: The Marine must execute the following tasks without being heard by a listener 40m away:

- a. Walk
- b. Establish a poncho shade. Using poncho to mask the light, check map or gear with flashlight.
- c. Remove canteen and drink. Replace canteen.
- d. Establish sleeping position. Set out sleeping bag, isopor mat, and bivvy sack. Remove boots and blouse. Climb into sleeping bag.
- e. Change socks and skivvy shirt. Dress.
- f. Roll up sleeping position. Pack gear and move out.
- g. With weapon: FIX BAYONETS (if M-16A2).
- h. With weapon: LOAD.
- i. With weapon: MAKE READY.
- j. With weapon: Turn safety in order to FIRE. Click of safety should NOT be heard.

NOTES: Additional tasks can be added by unit leaders: Heat and eat an MRE. Urinate and defecate. Build a poncho hooch.

9. TASK: Execute an individual night infiltration

CONDITIONS: With helmet, flak, deuce gear and weapon. Without pack. In the dark. With or without NVGs.

STANDARD: The Marine must infiltrate 1000m without being detected by an enemy OP.

NOTES:

- a. A time limit is set to fit local conditions. Marines move as individuals, not units. Helmets and flaks are required because this task supports the night attack.

b. See MCO 1510.35C task *0311.4.1 Execute an Infiltration*.

Section 1.2

Qualification Standards for

Night Warrior Leader

The following Individual Training Standards (ITS) define the Night Warrior Leader (NWL) Qualification. The NWL qualification sets the minimum ITS required for leaders. The Night Warrior Basic Qualification is a prerequisite. All infantry leaders, from squad leader and up, are expected to be NWL qualified. Existing ITS from MCO 1510.35C *Individual Training Standards for Infantry* are referenced.

- 1. Boresight PAQ-4C (or PEQ-2A) to M-16A2, M-203, and M-249**
- 2. Navigate at night with PVS-7 (or PVS-14)**
- 3. Read a map at night with PVS-7 (or PVS-14)**
- 4. Operate IR Signals**
- 5. Mark a target at night with a Hand-held Laser Pointer**
- 6. Control fire with a Hand-held Laser Pointer**
- 7. Plan an infiltration**
- 8. Operate PLGR at night**

1. TASK: Boresight PAQ-4C (or PEQ-2A) to M-16A2, M-203, and M-249

CONDITIONS: In the dark. With one or more Marines armed with the M-16A2, M-203 or M-249. With a PAQ-4C mounted to each weapon. With NVGs on each Marine. On a BZO range with BZO targets.

STANDARD: The Marine must supervise three separate boresight procedures such that Marines firing each weapon type attain an accurate PAQ-4C boresight.

NOTES:

- a. Boresight procedures differ with each mount. The Marine Corps has PAQ-4C mounts for M-16A2 and the reference explains M-16A2 boresight procedures.
- b. The Marine Corps has acquired PAQ-4C mounts for M-203, but has not published boresight procedures.
- c. The Marine Corps has not yet acquired PAQ-4C mounts for the M-249, so Marines must use expedient methods for mounting. Expedient mounts can only be roughly boresighted.
- d. A Laser Boresight System, designed to allow dry-fire boresighting of any weapon to any optic, will be fielded in 2001.
- e. MCO 1510.35C tasks *0300.2.6 Boresight the AN/PAQ-4B IAL to the M-16A2* and task *0311.2.10 Boresight the AN/PAQ-4B IAL to the M-249* apply only to the '-B' model which the Marine Corps never acquired.
- f. The PEQ-2A, an upgrade of the PAQ-4C, will be fielded in 2001. Boresight procedures for PEQ-2A will be published in the new technical manual.

REFERENCE: TM 09596C-12&P/1A *PAQ-4C Infrared Aiming Light*

2. Navigate at night with PVS-7 (or PVS-14)

CONDITIONS: In the dark. With PVS-7 (or PVS-14). With the following equipment: map, compass, protractor, flashlight, poncho, pencil, and notebook. Given 6-digit grids of specified points. Without GPS.

STANDARD: The Marine must navigate to each specified point within an established time period.

- a. For simple ded reckoning: (5) legs of 300-800m each.
- b. For true route navigation: (5) legs of 2000-2500m each.

NOTES: Time standards must be set locally.

REFERENCE: FM 21-26 *Map Reading and Land Navigation*

3. TASK: Read a map at night with PVS-7 (or PVS-14)

CONDITIONS: In the dark. With PVS-7 (or PVS-14). With the following equipment: map, compass, protractor, flashlight, poncho, pencil, and notebook.

STANDARD: The Marine must execute the following tasks to the indicated standard:

- a. Determine the 6-digit coordinate of a specified point. Error: +/-100m (horiz & vert)
- b. Find a specified point given a 6-digit coordinate. Error: +/-100m (horiz & vert)
- c. Identify (6) natural features on the map
- d. Identify (6) man-made feature on the map
- e. Measure straight-line distance. Error: +/-200m (min dist 4000m)

- f. Measure curved line distance. Error: +/-200m (min dist 4000m)
- g. Perform modified 1-point resection. Error: +/-100m (horiz & vert)
- h. Perform resection . Error: +/-100m (horiz & vert)
- i. Perform modified 1-point intersection. Error: +/-100m (horiz & vert)
- j. Perform intersection. Error: +/-100m (horiz & vert)
- k. Determine elevation of a point
- l. Determine grid zone designator and full 11-character grid description of a point
- m. Orient the map with a compass

NOTES: This task is best evaluated as a map test in the field. Due to difficulties in map reading with NVGs, a second man should be assigned to each Marine to read and take notes.

REFERENCE: FM 21-26 *Map Reading and Land Navigation*

4. TASK: **Operate IR Signals**

CONDITIONS: In the dark. With the following equipment: PVS-7 (or PVS-14), Phoenix Beacon, Firefly IR Beacon, M-203, (5) IR chemlights, 550 cord, and (5) nails.

STANDARD: The Marine must execute the following signal procedures to the indicated standard:

- a. Program a Phoenix beacon with a given code.
- b. Setup a Firefly IR beacon.
- c. With an M-203 tube, make a Phoenix or Firefly beacon directional.
- d. With an IR chemlite and 550 cord, construct and execute a "Buzzsaw" signal.
- e. With (5) IR chemlights, 550 cord and nails, layout and stake a wind "T" for an LZ.

NOTE: Additional signal device standards can be added locally by commanders to support unit SOPs.

5. TASK: **Mark a target at night with a Hand-held Laser Pointer.**

CONDITIONS: At night, on a range with targets of at least 200m. Marine is equipped with a hand-held laser pointer (LPL-30, PEQ-4, IZ-LID II, or GCP) and PVS-7 (or PVS-14).

STANDARD: Using a hand-held laser pointer, the Marine will:

- a. "Rope" his location with the IR beam.
- b. "Snake" a target at least 200m away with the IR beam.

- c. "Steady" the IR beam on the target.
- d. "Shift" the IR beam to a new target.
- e. State the meaning and use of the laser terms "Stop" and "Terminate."

NOTES:

- a. The PAQ-4C can be used in the hand-held mode, but it cannot be seen from a distance.
- b. The same standard laser terms and actions apply to a Marine controlling the organic fires of his unit, a Marine controlling non-organic fires (TOW, HMG, AT) of a supporting unit, or a Marine controlling CAS aircraft.

REFERENCES:

- a. MCWP 3-23.1 *Close Air Support*
- b. MAWTS-1 *Forward Air Controller (Airborne) Handbook*
- c. MCRP 3-16.8B *J-FIRE Multiservice Procedures for Firepower*
- d. Joint Pub 3-09.3 *Tactics, Techniques, and Procedures for CAS*

6. TASK: Control fire with a Hand-held Laser Pointer

CONDITIONS: On the range with targets ranging from 100m to 400m. With a squad of Marines, equipped with weapons, ammunition, PAQ-4C (or PEQ-2A), and PVS-7 (or PVS-14). With a Hand-held laser pointer.

STANDARD: Using tracer fire, PAQ-4C, a Hand-held Laser Pointer, and voice ADDRACs, the Marine will:

- a. Establish sectors of fire.
- b. Concentrate all fire on a single target. Shift all fire to a new target.
- c. Distribute fire among three specified targets.
- d. Cease fire of one team. Cease fire of the squad.

Using a radio to a support-by-fire unit and a Hand-held Laser Pointer, the Marine will:

- e. Identify targets.
- f. Direct fire of non-organic weapons.

7. TASK: Plan an infiltration

CONDITIONS: Given an infiltration mission as part of a larger force, to include infiltration lanes, time windows, control measures, and linkup requirements.

STANDARD: The Marine must plan an infiltration of at least (2) kilometers. The Marine must issue his unit order on a

terrain model. The order must cover at a minimum:

- a. Orientation. Specifics of terrain. Control Measures. Collecting features, catching features.
- b. Situation. Night planning considerations: moonrise, moonset, %illum, EENT, BMNT.
- c. Mission.
- d. Execution. Scheme of Maneuver. Tasks.
- e. Coordinating Instructions: Route Plan. Linkup SOP. Contingencies.

NOTES:

- a. Executing a unit infiltration is a collective task, not an individual skill.
- b. For related standards, see MCO 1510.35C task *0300.4.3 Select Routes Using a Map* and task *0311.4.2 Lead an Infiltration Group*.

REFERENCE: FMFM 6-7 *Scouting and Patrolling for Infantry Units*

8. TASK: **Operate PLGR at night**

CONDITIONS: In the dark. With a PLGR containing the correct crypto fill. With the PLGR not currently set to the proper defaults. With a spare power battery. With a map.

STANDARD: The Marine must execute the following tasks:

- a. In (2) minutes: Remove old power battery. Insert new power battery.
- b. In (2) minutes: Set PLGR defaults for foot-mobile infantry:

SETUP MODE: CONT, SV-TYPE: all-Y, SETUP UNITS: MGRS-New Metric, Elevation: (map specific), ANGL: Deg Mag, SETUP MVAR TYPE: Calc, ELHold: automatic, Time, ERR: +-m, SETUP DATUM: (map specific), Automatic OFF TIMER: 5 min, Serial: Standard, HAVEQUICK: OFF, 1PPS: Off.

- c. Calculate current ground position. State position using full grid zone designator.

NOTES:

- a. This task is the Level III PLGR qualification. See *The PLGR Primer* for Levels I-III.
- b. Horizontal Datum and elevation information must be taken from map of current location.
- c. User interface varies between PLGRs due to different software versions.

REFERENCE: *The PLGR Primer*, Camp Pendleton, 2nd Battalion, 5th Marines: 1999.

Section 1.3

Qualification Standards for
Night Warrior Weapons

The Night Warrior Weapons (NWW) Qualification is intended for the Weapons Platoon of the Infantry Company. All Weapons Platoon Marines will qualify on those ITSs that apply to their MOS: Tasks 1-4 for 0351, Task 5 for 0341, and Tasks 6-9 for 0331.

- 1. Boresight PAQ-4C (or PEQ-2A) to Mk153 SMAW**
- 2. Engage target at night with Mk153 SMAW, PVS-7 (or PVS-14), and PAQ-4C (or PEQ-2A)**
- 3. Boresight PVS-4 (or PVS-17) to the Mk153 SMAW**
- 4. Engage target at night with Mk153 SMAW and PVS-4 (or PVS-17)**
- 5. Engage target at night with M-224 Mortar in hand-held mode and PVS-7 (or PVS-14)**
- 6. Operate the PAS-13 TWS**
- 7. Boresight the PAS-13 TWS to the M-240G**
- 8. Engage target at night with M-240G and PAS-13 TWS**
- 9. Engage target at night with M-240G, PVS-7 (or PVS-14) and PAQ-4C (or PEQ-2A)**

1. TASK: Boresight PAQ-4C (or PEQ-2A) to Mk153 SMAW

CONDITIONS: With a Mk153 SMAW and (10) spotting rounds. With a PAQ-4C (or PEQ-2A). With PVS-7 (or PVS-14). With a BZO range and target.

STANDARD: The Marine must boresight the PAQ-4C to the Mk153 SMAW.

NOTES:

- a. The PEQ-2A, an upgrade of the PAQ-4C, will be fielded in 2001.
- b. The Laser Boresight System, to be fielded in 2001, will boresight any optic to any weapon without requiring live rounds.
- c. There is no approved PAQ-4C mount for the Mk153. When the telescopic sight is removed from the Mk153 SMAW, the PAQ-4C can be mounted, inverted, to the railing.

REFERENCE: TM 09596C-12&P/1A *PAQ-4C Infrared Aiming Light*

2. TASK: Engage target at night with Mk153 SMAW, PVS-7 (or PVS-14), and PAQ-4C (or PEQ-2A)

CONDITIONS: In the dark. With a Mk153 SMAW and a PAQ-4C (or PEQ-2A) properly mounted and boresighted. Wearing PVS-7 (or PVS-14). With a target 150m to 200m downrange.

STANDARD: The Marine must hit the target without using spotting rounds.

NOTES: This individual task should be evaluated without input from the assistant gunner.

3. TASK: Boresight PVS-4 (or PVS-17) to the Mk153 SMAW.

CONDITIONS: With a Mk153 SMAW and (10) spotting rounds. With a PVS-4 (or PVS-17) mounted to the Mk153 SMAW. With a BZO range and BZO target.

STANDARD: The Marine must boresight the PVS-4 to the Mk153 SMAW.

NOTES:

- a. The Laser Boresight System, to be fielded in 2001, will boresight any optic to any weapon without requiring live rounds.
- b. The PVS-17 scope will replace the PVS-4 in 2001.

REFERENCE: TM 11-5855-213-10 *Operator's Manual for Night Vision Sight, AN/PVS-4*

4. TASK: Engage target at night with Mk153 SMAW and PVS-4 (or PVS-17)

CONDITIONS: In the dark. With a Mk153 SMAW and PVS-4 (or PVS-17) properly mounted and boresighted to the weapon. With a target 150m to 200m downrange.

STANDARD: The Marine must hit the target without using spotting rounds.

NOTES:

- a. This individual task should be evaluated without input from the assistant gunner.
- b. The PVS-17 scope will replace the PVS-4 in 2001.

REFERENCE: TM 11-5855-213-10 *Operator's Manual for Night Vision Sight, AN/PVS-4*

5. Engage target at night with M-224 Mortar in hand-held mode and PVS-7 (or PVS-14)

CONDITIONS: In the dark. With an M-224 60mm mortar and M-7 assault baseplate set up the hand-held mode. Wearing PVS-7 (or PVS-14) and 3X magnifier. With an assistant gunner to watch the range indicator and load the weapon. With (3)

HE rounds. With a target 400m to 600m downrange.

STANDARD: In (3) minutes, the Marine must hit (1) round within 100m of the target.

NOTES: The assistant gunner does not wear NVGs to watch the range indicator.

6. TASK: **Operate the PAS-13 TWS**

CONDITIONS: In the dark. With a PAS-13 TWS and (2) AA batteries. Without NVGs.

STANDARD: The Marine must execute the following within (2) minutes:

- a. Remove old batteries. Insert new batteries.
- b. Turn PAS-13 TWS on. Adjust gain. Focus objective lens.
- c. Identify a detailed object at 50m.
- d. State the meaning of the red dot indicator.

NOTES: The PAS-13 Thermal Weapons Sight will be fielded in 2002.

7. TASK: **Boresight the PAS-13 TWS to the M-240G**

CONDITIONS: In the dark. With a tripod-mounted M-240G. With a PAS-13 TWS. Without NVGs. With (50) rounds. On a BZO range with BZO targets.

STANDARD: The Marine must execute the following tasks:

- a. Mount the PAS-13 TWS to the M-240G.
- b. Boresight the PAS-13 TWS to the M-240G.

NOTES:

- a. The PAS-13 Thermal Weapons Sight will be fielded in 2002.
- b. The Laser Boresight System, to be fielded in 2001, will boresight any optic to any weapon without requiring live rounds.

8. TASK: **Engage target at night with M-240G and PAS-13 TWS**

CONDITIONS: In the dark. With a tripod-mounted M-240G. With a PAS-13 TWS properly mounted and boresighted to the weapon. Wearing helmet, flak and deuce gear. Without NVGs. With (100) rounds. With (5) targets located 400m to 600m downrange.

STANDARD: The Marine must hit each target.

NOTES:

- a. The PAS-13 Thermal Weapons Sight will be fielded in 2002.
- b. This individual task should be evaluated without input from the assistant gunner.

9. TASK: Engage target at night with M-240G, PVS-7 (or PVS-14) and PAQ-4C (or PEQ-2A)

CONDITIONS: In the dark. With a tripod-mounted M-240G. With a PAQ-4C properly mounted and boresighted to the weapon. Wearing helmet, flak and deuce gear. With NVGs. With (100) rounds. With (5) targets located 400m to 600m downrange.

STANDARD: The Marine must hit each target.

NOTES:

- a. The M240G will be upgraded with a MIL-STD-1913 rail feed tray cover, allowing the PAQ-4C and other weapons accessories to be mounted. The Laser Boresight System, to be fielded in 2001, will boresight any optic to any weapon without requiring live rounds.
- b. This individual task should be evaluated without input from the assistant gunner.

Section 1.4

Additional Night Warrior Standards

The following additional Individual Training Standards (ITS) are not part of any qualification. Leaders select those ITSs that apply to specific Marines and specific missions. The NWB qualification is a prerequisite.

- 1. Operate PVS-4 (or PVS-17) on M-203 (or M-16A2)**
- 2. Boresight PVS-4 (or PVS-17) to M-203 (or M-16A2)**
- 3. Engage targets at night with PVS-4 (or PVS-17) on M-203 (or M-16A2)**
- 4. Engage target at night with AT-4 and PAQ-4C (or PEQ-2A)**
- 5. Setup and detonate M-18A1 Claymore mine in the dark**

6. Control CAS at night with a Hand-held Laser Pointer

7. Boresight the PVS-13 to the PEQ-1A SOFLAM

8. Designate a target at night with the PEQ-1A SOFLAM and PVS-13

9. Control CAS at night with the PEQ-1A SOFLAM and PVS-13

1. TASK: Operate PVS-4 (or PVS-17) on M-203 (or M-16A2)

CONDITIONS: In the dark. With an M-203 and PVS-4. With the PVS-4 not mounted to the weapon. Without the aid of NVGs. With a spare battery.

STANDARD: The Marine must execute the following tasks silently within 3.5 minutes:

- a. Install battery adapter.
- b. Remove old batteries. Insert new batteries.
- c. Mount the PVS-4 to the weapon.
- d. Turn PVS-4 on. Identify target 100m away.

The Marine must then execute the following untimed task:

- e. Using M16 / M203 reticle, determine range of given man-sized target.

NOTES:

- a. PVS-4 can be mounted to either M-16A2 or M-203.
- b. Boresighting the PVS-4 to the M-203 (or M-16A2) is a separate task.
- c. Standard 'e' can be accomplished using a graphic training aid.
- d. See MCO 1510.35C task *0300.2.2 Maintain the AN/PVS-4 Individual Weapon Night Vision Sight*
- e. The PVS-17 scope will replace the PVS-4 in 2001.

REFERENCE: TM 11-5855-213-10 *Operator's Manual for Night Vision Sight, AN/PVS-4*

2. TASK: Boresight PVS-4 (or PVS-17) to M-203 (or M-16A2)

CONDITIONS: With an M-203 (or M-16A2) loaded with (10) rounds. With a PVS-4 (or PVS-17) properly mounted to the weapon. With a BZO range and BZO target.

STANDARD: The Marine must boresight the PVS-4 to the M-203 (or M-16A2)

NOTES:

- a. If a PAQ-4C is mounted and boresighted to the weapon, the PVS-4 (or PVS-17) does NOT need to be boresighted. The shooter ignores the reticle of the PVS-4 and places the PAQ-4C beam on the target.
- b. The Laser Boresight System, to be fielded in 2001, will boresight any optic to any weapon without requiring live rounds.
- c. The PVS-17 scope will replace the PVS-4 in 2001.

REFERENCE: TM 11-5855-213-10 *Operator's Manual for Night Vision Sight, AN/PVS-4*

3. TASK: Engage Targets at Night with PVS-4 (or PVS-17) on M-203 (or M-16A2)

CONDITIONS: In the dark. With an M-203 and PVS-4. With the PVS-4 mounted and boresighted to the weapon. With NVGs. With 20 rounds loaded. Wearing helmet, flak, and deuce gear. With (5) targets located 100m downrange. Each target is 'live' for only (5) seconds. (10) rounds prone, (5) rounds kneeling, and (5) rounds offhand.

STANDARD: The Marine must hit the target with 14 or 20 rounds (70%).

NOTES:

- a. PVS-4 can be mount to either M-16A2 or M-203.
- b. Boresighting PVS-4 is a separate task. If a PAQ-4C is mounted and boresighted to the weapon, the PVS-4 does NOT need to be boresighted. The shooter ignores the reticle of the PVS-4 and places the PAQ-4C beam on the target.
- c. This standard does NOT include 40mm grenades.
- d. See MCO 1510.35C task *0300.2.4 Engage Targets with the M16A2 using the AN/PVS-4 Night Vision Sight*.

REFERENCE: TM 11-5855-213-10 *Operator's Manual for Night Vision Sight, AN/PVS-4*

4. TASK: Engage target at night with AT-4 and PAQ-4C (or PEQ-2A)

CONDITIONS: In the dark. With an AT-4. With a PAQ-4C mounted to the AT-4. Wearing PVS-7 (or PVS-14). Wearing helmet, flak, and deuce gear. With a target 150m to 250m downrange.

STANDARD: The Marine must hit the target with the AT-4.

NOTES:

- a. No PAQ-4C mount exists for the AT-4. PAQ-4C must be mounted using expedient methods.
- b. The PVS-4 (or PVS-17) can also be mounted to an AT-4 using expedient methods.
- c. This task can be trained using an expended AT-4 rocket.

5. TASK: **Setup and detonate M-18A1 Claymore mine in the dark**

CONDITION: In the dark. With an M-18A1 Claymore mine. Wearing PVS-7 (or PVS-14). On the range with a designated target area and a designated safe area.

STANDARD: The Marine must execute the following tasks in (5) minutes:

- a. Test detonator.
- b. Set up M-18A1 Claymore mine to cover designated target area.
- c. Move from target area to safe area.
- d. Detonate the M18A1 Claymore mine

NOTES: This task can be trained with a simulated M-18A1 Claymore mine.

6. TASK: **Control CAS at night with a Hand-held Laser Pointer**

CONDITIONS: At night, on a range with targets at distances of at least 600m. Equipped with a hand-held laser pointer (LPL-30, PEQ-4, or IZLID II), PVS-7 (or PVS-14), and either a PRC-113 or PRC-119. With fixed-wing or rotary-wing aircraft in support. With callsigns and frequencies.

STANDARD: Using a Hand-held Laser Pointer, the Marine will:

- a. Determine the most advantageous attack axis for the pilot to be able to see the IR mark.
- b. Pass a 9-line brief to the aircraft.
- c. Mark the target with the Hand-held Laser Pointer.
- d. Clear the aircraft hot onto the target.
- e. Throughout the procedure, demonstrate the proper actions for the terms "Rope", "Snake", "Steady", "Shift", "Stop", and "Terminate."

NOTES:

- a. This standard can be accomplished with actual aircraft conducting SIMCAS. No ordnance is required.
- b. This standard requires the Marine to communicate by radio with pilots in actual aircraft.

REFERENCES:

- a. MCWP 3-23.1 *Close Air Support*
- b. MAWTS-1 *Forward Air Controller (Airborne) Handbook*
- c. MCRP 3-16.8B *J-FIRE Multiservice Procedures for Firepower*
- d. Joint Pub 3-09.3 *Tactics, Techniques, and Procedures for CAS*

7. TASK: Boresight the PVS-13 to the PEQ-1A SOFLAM

CONDITION: In the daytime or dusk with a PEQ-1A SOFLAM, tripod, and (5) BA-5590 batteries. With a PVS-13 and (2) AA batteries.

STANDARD: The Marine must execute the following within (6) minutes.

- a. Mount the PEQ-1A SOFLAM to the tripod.
- b. Insert (5) BA-5590 batteries into the battery bag case, connect case to the PEQ-1A SOFLAM.
- c. Turn the PEQ-1A SOFLAM on.
- d. Select a target for boresighting.
- e. Insert (2) AA batteries into the PVS-13.
- f. Mount the PVS-13 to the PEQ-1A SOFLAM.
- g. Turn the PVS-13 on.
- h. Adjust the view of the target with the Objective and Eyepiece focus ring. Adjust the reticle brightness with the Reticle Brightness Knob.
- i. Using the Reticle Windage and Elevation Knobs, boresight the PVS-13 to the same target as the PEQ-1A SOFLAM.

NOTES:

- a. The PVS-13 is mounted on the weaver rail above the eyepiece on the PEQ-1A SOFLAM.
- b. Laser Safety precautions must be taken at all times.
- c. The Laser Boresight System, to be fielded in 2001, will boresight any optic to any weapon without requiring live rounds.

8. TASK: Designate a target at night with the PEQ-1A SOFLAM and PVS-13

CONDITION: With a PEQ-1A SOFLAM, properly mounted and set up. With a PVS-13 properly mounted and boresighted. With a designated target at least 600m downrange.

STANDARD: The Marine must execute the following tasks within (2) minutes:

- a. Find the range to the designated target.
- b. Change the laser code to a given code.
- c. Laze the designated target.

NOTES: Laser Safety precautions must be taken at all times.

9. TASK: Control CAS at night with the PEQ-1A SOFLAM and PVS-13

CONDITIONS: At night, on a range with targets at distances of at least 600m. With a PEQ-1A SOFLAM and PVS-13 properly setup and boresighted. With either a PRC-113 or PRC-119. With fixed-wing or rotary-wing aircraft in support. With callsigns and frequencies.

STANDARD: The Marine will:

- a. Determine the most advantageous attack axis for the pilot to be able to see the IR mark.
- b. Pass a 9-line brief to the aircraft.
- c. Designate the target with the PEQ-1A SOFLAM.
- d. Clear the aircraft hot onto the target.

NOTES:

- a. This standard can be accomplished with actual aircraft conducting SIMCAS. No ordnance is required.
- b. Laser safety precautions must be taken at all times.
- c. This standard requires the Marine to communicate by radio with pilots in actual aircraft.

REFERENCES:

- a. MCWP 3-23.1 *Close Air Support*
- b. MAWTS-1 *Forward Air Controller (Airborne) Handbook*
- c. MCRP 3-16.8B *J-FIRE Multiservice Procedures for Firepower*
- d. Joint Pub 3-09.3 *Tactics, Techniques, and Procedures for CAS*

Chapter 2

Equipment Training for Individuals

Section 2.1

Night Vision Goggles

PVS-7

PVS-7 Data Sheet
PVS-7 Training Handout
How to Focus PVS-7
PVS-7 Tactics, Techniques and Procedures

PVS-14

PVS-14 Data Sheet
PVS-14 Training Handout
PVS-14 Tactics, Techniques and Procedures

3X Magnifier

3X Magnifier Data Sheet

PVS-7

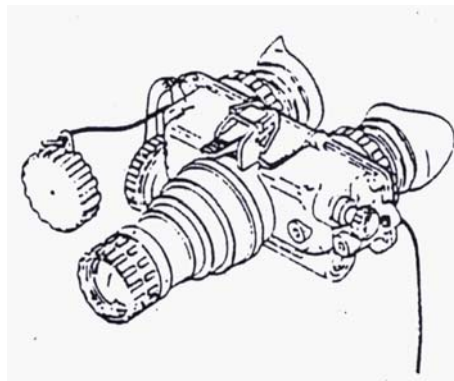

1. Nomenclature:

AN/PVS-7B Night Vision Goggles (NVGs)
AN/PVS-7D Night Vision Goggles (NVGs)

2. NSN:

7B: 5855-01-228-0937

7D: 5855-01-422-5413

3. Manual:

TM 11-5855-262-10-02 *Operator's Manual, NVG AN/PVS-7B*, 15 Jul 1994

TM 09500A-10/1A, 30 Dec 1997

4. Description:

PVS-7 Night Vision Goggles allow the user to see at night using moonlight or starlight. PVS-7s can be hand held, head-mounted, or helmet-mounted. The goggles have an IR illuminator for illumination or signaling. An indicator lets the user know when the IR light is on. A separate indicator signals low battery. Automatic shutoff occurs on high light, when goggle is detached from the head mount, or flipped up on the helmet mount.

5. Characteristics:

Weight: 18 oz

Focus Range: 20 cm to Infinity

Range: 150 m (Starlight), 300 m (Moonlight)

Battery: (2) AA or (1) BA-5567/U

Battery Life: 4-6 hours

Magnification: 1X

Field of View: 40°

Interpupillary Adjustment: 55 to 71 mm

6. Accessories:

PVS-7s include a helmet mount and a head mount. The 7D include a compass. A 3X Magnifier attachment is available.

7. Limitations:

In complete darkness, such as inside buildings, PVS-7s are ineffective without IR illumination. The compass is 15° off. The IR illuminator illuminates only at a short range. The IR illuminator is visible to an enemy with NVGs. The helmet mount unbalances the helmet and causes neck fatigue. The 7B carrying case has a noisy velcro closure.

8. Usage Notes: The IR illuminator works well as a recognition signal during link-ups.

9. Supplier:

Marine Corps Issue. TAMCN: E1152 II BP. \$3578.00

ITT Night Vision, 7635 Plantation Road, Roanoke, VA 24019, (800) 533-5502, (540) 563-0371, FAX (540) 366-9015, <http://www.ittnv.com>

PVS-7 Training Handout

Ref: TM 09500A-10/1A, 30 Dec 1997

1. PVS-7 Night Vision Goggles allow the user to see at night using moonlight or starlight.

2. Major components and their purposes

PVS-7D have an (18)-item SL-3 Gear List. See Reference, pages B-4 through B-8.

- **Goggles & Lens Cap** to protects lens.
- **Demist Shields** (2) for high humidity and rain. Degrades visual acuity.
- **Light Interference Filter** (LIF) to protect eyes from lasers.
- **Sacrificial Window** to protect lens from dust and sand scratches.
- **IR Flood Lens** to adjust IR beacon from spot to flood.
- **Compass** to orient at night.
- **Tether Cord** to dummy cord compass or 3X Magnifier Lens.
- **Head Mount & (3) Browpads** to mount goggles on head.
- **Helmet Mount** to mount goggles on helmet.
- **Carrying Case & Strap** to carry goggles.
- **Storage Case** to store goggles and all accessories.
- **Operator's Manual**

Older PVS-7Bs were not issued with a Helmet Mount, Compass, Tether Cord, or IR Flood Lens. The helmet mount, NSN 5855-01-441-0401, is far easier to use and should be back-ordered for 7Bs.

A **3X Magnifier Lens** is available as an optional accessory. See Reference, pages C-2 through C-3.

3. Battery Installation. Either (1) BA-5567/U or (2) AA alkaline.

4. Indicator Lights

LOW BATTERY - Red dot in right eyepiece.

IR beacon is ON - Red dot in left eyepiece.

5. Switch

OFF / RESET - turns goggles OFF. Resets Goggles after automatic shutoff.

ON - turns goggles ON.

IR - turns IR beacon ON. Pull and turn. New goggles have temporary ON.

6. Automatic Shutoff

Goggles shut off automatically in Excessive Light, when the goggles are removed from the Head Mount,

or when the goggles are flipped up from the Helmet Mount. To turn goggles back on, turn switch to OFF / RESET, then back to ON position.

7. Goggle Adjustments. PVS-7s have four (4) adjustments:

Interpupillary Distance. The two eyepieces slide apart to adjust to the user's interpupillary distance. Adjust the Interpupillary Distance so that each eye views each lens as a perfect circle.

Eye Relief. On the head mount and the helmet mount, the distance from the goggles to the user's eyes needs to be adjusted as close to the eyes as is comfortable.

Objective Lens Focus. The main lens rotates to focus on objects closer or farther away.

Diopter focus. Each eyepiece adjusts independently to focus each eye on the image inside the goggles. Turn objective lens to focus on an object 20 feet away. Once focused, turn left diopter ring counterclockwise all the way. Close right eye. Turn left diopter ring clockwise until image first becomes clear. *Do not turn past this point.* Repeat this adjustment for right eyepiece, then re-adjust objective lens focus.

8. Maintenance

Clean lens with lens paper. Turn in for maintenance if goggles have shading, edge glow, flashing, flickering, or operate intermittently. Some blemishes or spots are not deadline issues. Goggle resolution can only be adjusted by higher echelon maintenance.

9. Mounts

Always wear the PVS-7 on a mount. NVGs are not opera glasses to be worn around the neck and lifted to the eyes when needed. This requires one hand, making it impossible to shoot. The helmet mount is far superior to the head mount. On operations where helmets are not usually worn, such as boat raids, leaders may direct Marines to wear helmets solely as a platform for the PVS-7. Marines should be able to assemble all mount hardware in the dark.

Head Mount. Don Head Mount and adjust straps. Attach goggles to mount. Adjust Eye Relief by sliding mounting bracket toward or away from eyes.

Helmet Mount. Strap Helmet Mount onto helmet. Attach goggles to Mount. Adjust goggle height by loosening bracket knob and sliding goggles up and down. Adjust Eye Relief by sliding mounting bracket toward or away from eyes. Goggles can be flipped up when not in use.

10. Pre-Combat Checks

Install batteries.

Remove Lens Cap. Attach Sacrificial Window OR Compass OR 3X Magnifier.

Attach IR Flood Lens.

Don and Adjust Head Mount OR Helmet Mount.

Make the four (4) goggle adjustments.

11. IR Beacon

The IR Beacon is for illuminating near objects in very dark conditions, or for signaling. The IR beacon CAN be detected by an enemy with NVGs. Newer goggles have a momentary ON feature. Turn Beacon ON by pulling switch out and forward. Red dot in left eye indicates IR is ON. Flood Lens attachment allows beacon to adjust from spot to flood.

How to Focus PVS-7

1. Set Up

Install batteries in PVS-7. Don and adjust Head Mount or Helmet Mount. Attach PVS-7.

Stand behind 20-foot line.

Turn lights OFF. Turn PVS-7 ON. Turn IR illuminator ON.

2. Make the (4) PVS-7 goggle adjustments

Adjust Interpupillary Distance. Slide eyepieces closer or farther apart so that each eye views each lens as a perfect circle.

Adjust Eye Relief. On the head mount and the helmet mount, adjust PVS-7 as close to the eyes as is comfortable to acquire maximum field of view. Lens caps should cover eyes.

Adjust Objective Lens. Turn Objective Lens fully counterclockwise. Rotate Objective Lens clockwise until both vertical and horizontal charts are clearly in focus.

Adjust each Diopter Ring. Turn both Diopter Rings fully counterclockwise. Close right eye. Turn left Diopter Ring clockwise until image first becomes clear. *Do not turn past this point.* Repeat this for right eyepiece. Re-adjust Objective Lens.

3. Afterwards, when re-focusing for distance, adjust Objective Lens ONLY. Do NOT re-adjust Diopter Rings.

Xerox this page and next page. See bottom of next page for instructions on how to set up a PVS-7 focus lane.

PVS-7 Adjustment Chart

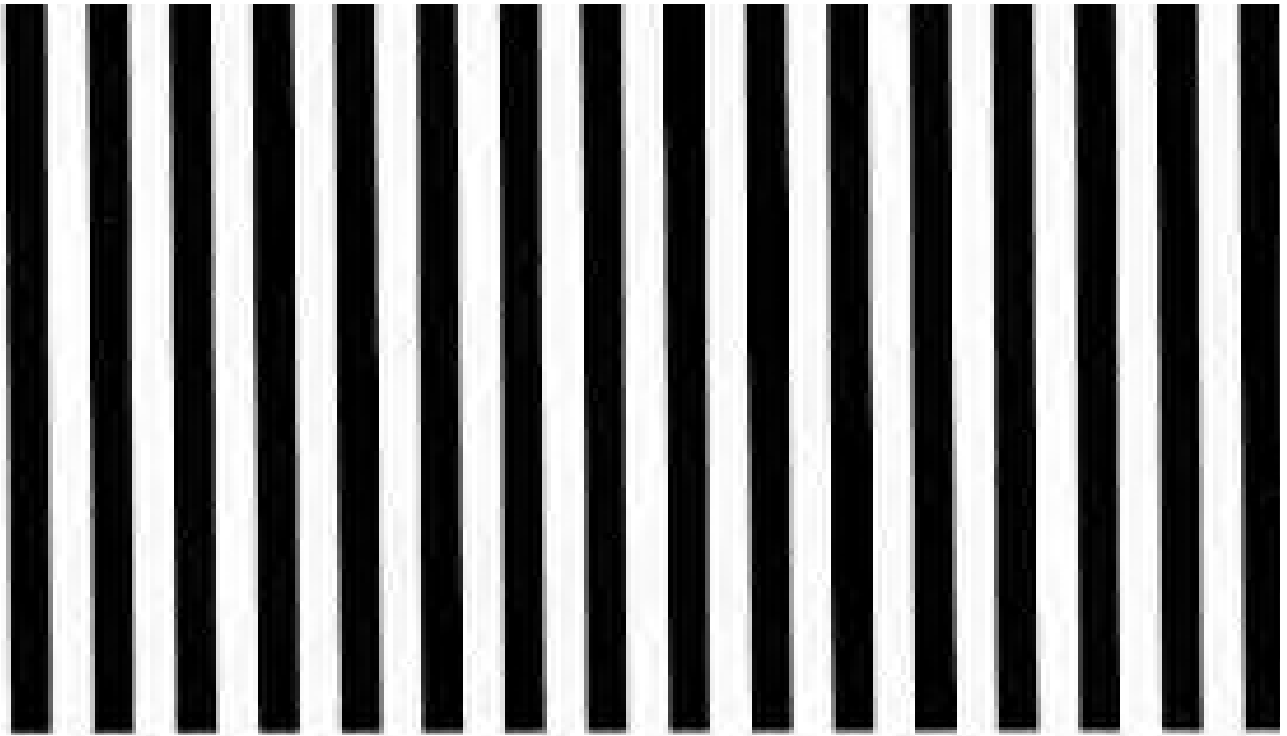

How to use this chart to establish a PVS-7 focus lane. Xerox this page and previous page. In a room or hallway with no windows, tape this chart to bulkhead. Place a tape line on the deck 20 feet away from this chart.

Paste the "How to Focus PVS-7" instructions on the bulkhead next to the tape line.

PVS-7 TTP

1. Fire the M-16A2 with PVS-7 and PAQ-4C

Procedure. Focus PVS-7 to infinity. Establish solid firing position with butt of weapon in shoulder or crook of arm. Do NOT attempt to align head with sights or establish stock weld. Acquire target using PVS-7. Activate PAQ-4C beam. Adjust PAQ-4C spot onto target. Pull trigger.

Techniques

- Tracer rounds are not needed and not recommended, except for unit leaders who need to control fires.
- Magazine change drills and immediate action drills need to be executed without looking. NVGs cannot be quickly re-focused onto magazine pouches or rifle for these actions.

Common Errors

- Using the PAQ-4 in continuous mode. Do NOT 'search' the battlefield. Use the PAQ-4 beam only when engaging targets. Unit leaders, using lasers to control fire, need to control their men's use of individual weapons laser pointers.
- Mistaking another Marine's PAQ-4C beam for your own.
- Not boresighting the PAQ-4C.
- Attempting to use the sights. The iron sights of the M-16A2 have absolutely NO effect on PAQ-4C accuracy. The weapon's BZO, or lack of BZO, has NO effect on PAQ-4C accuracy.
- Firing without PAQ-4C. PVS-7 without a PAQ-4C allows the shooter to acquire targets but the shooter cannot use iron sights and PVS-7 does not improve accuracy.

2. Fire the M-203 with the PVS-7 and PAQ-4C

Procedures

- For 5.56mm, see TTP 1., above. The M-203 PAQ-4C mount is harder to use than the M-16A2 mount.
- For 40mm grenades, PVS-7 allow the shooter to acquire targets, but the goggles cannot be quickly re-focused onto the weapon to use the leaf or quadrant sights.

Techniques

Common Errors

3. Fire the M-249 with PVS-7 and PAQ-4C

Procedure. Focus PVS-7 to infinity. Establish solid firing position with butt of weapon in shoulder. Do NOT attempt to align head with sights. Acquire target using PVS-7. Activate PAQ-4C beam. Adjust PAQ-4C spot onto target. Pull trigger.

Techniques

- Tracer rounds are not needed and are not recommended for PAQ-4C firing. Conversely, if the M-249 does NOT have a PAQ-4C, tracer rounds are the ONLY way to fire accurately at night.
- Ammunition reload drills, barrel change drills, and immediate action drills need to be executed without looking. NVGs cannot be quickly re-focused onto the weapon for these actions.

Common Errors

- Using the PAQ-4 in continuous mode. Do NOT 'search' the battlefield. Use the PAQ-4 beam only when engaging targets. Unit leaders, using lasers to direct fire, need to limit their men's use of individual weapons laser pointers.

- Mistaking another Marine's PAQ-4C beam for your own.
- Not boresighting the PAQ-4C. Until the Marine Corps acquires a PAQ-4C mount for the M-249, field expedient mounts will be difficult to accurately boresight.
- Attempting to use the sights. The iron sights of the M-249 have absolutely NO effect on PAQ-4C accuracy. The weapon's BZO, or lack of BZO, or range setting, has NO effect on PAQ-4C accuracy.
- Firing without PAQ-4C. PVS-7, used without a PAQ-4C, does allow the shooter to acquire targets but shooter cannot use iron sights and PVS-7 does not improve accuracy.

4. Fire the M-240G with PVS-7 and PAQ-4C

Procedure. Focus PVS-7 to infinity. Establish solid firing position with butt of weapon in shoulder. Do NOT attempt to align head with sights or establish stock weld. Acquire target using PVS-7. Activate PAQ-4C beam. Adjust PAQ-4C spot onto target. Pull trigger.

Techniques

- Tracer rounds are not needed and not recommended for PAQ-4C firing. Conversely, if the M-240G does NOT have a PAQ-4C, tracer rounds are the ONLY way to fire accurately at night.
- Ammunition reload drills, barrel change drills, and immediate action drills need to be executed without looking. NVGs cannot be quickly re-focused onto the weapon for these actions.

Common Errors

- Firing without an assistant gunner. M-240G muzzle flash 'whites-out' NVGs, making it hard for the gunner to adjust fire.
- Using the PAQ-4 in continuous mode. Do NOT 'search' the battlefield. Use the PAQ-4 beam only when engaging targets. Unit leaders, using lasers to direct fire, need to control their men's use of individual weapons laser pointers.
- Mistaking another Marine's PAQ-4C beam for your own.
- Not boresighting the PAQ-4C. Until the Marine Corps acquires a PAQ-4C mount for the M-240G, field expedient mounts will be difficult to accurately boresight.
- Attempting to use the sights. The iron sights of the M-240G have NO effect on PAQ-4C accuracy. The weapon's BZO, or lack of BZO, or range setting, has NO effect on PAQ-4C accuracy.
- Firing without PAQ-4C. PVS-7, used without a PAQ-4C, does allow the shooter to acquire targets but shooter cannot use iron sights and PVS-7 does not improve accuracy.

5. Fire the Mk153 SMAW with PVS-7 and PAQ-4C

Procedure. Remove optical sight. Mount PAQ-4C, inverted, to sight mount. Focus PVS-7 to infinity. Acquire target using PVS-7. Do NOT attempt to align head with sights. Activate PAQ-4C beam. Adjust PAQ-4C spot onto target. Do NOT fire spotting rounds. Pull trigger.

Techniques. Ammunition reload drills and immediate action drills need to be executed without looking. NVGs cannot be quickly re-focused onto the weapon for these actions. 3X magnifier can be used.

Common Errors

- Using the PAQ-4 in continuous mode. Do NOT 'search' the battlefield. Use the PAQ-4 beam only when engaging targets. Unit leaders, using lasers to direct fire, need to limit their men's use of individual weapons laser pointers.
- Mistaking another Marine's PAQ-4C beam for your own.
- Not boresighting the PAQ-4C. Until the Marine Corps acquires a PAQ-4C mount for the Mk153, field expedient mounting will be difficult to accurately boresight.
- Attempting to use the sight. Sights have NO effect on PAQ-4C accuracy.
- Firing without PAQ-4C. PVS-7, used without a PAQ-4C, does allow the shooter to acquire targets but shooter cannot use day sight and PVS-7 does not improve accuracy.

Note. See Section 2.3 for mounting, boresighting, and firing the Mk153 SMAW with PAQ-4C.

6. Fire the M-224 60mm Mortar in hand-held mode with PVS-7

Procedure. Setup mortar with M7 assault baseplate. Acquire target with PVS-7. Keep eye on target. Call out distance estimate to assistant gunner. Align tube with target. Assistant gunner, viewing luminous range scale, calls 'forward' or 'back' to adjust range and loads weapon. Pull trigger.

Techniques

Common Errors

- Task overload. One man cannot shift focus between target and luminous range scale.
- Range estimation is difficult at night. See TTP 11., below.
- Distant target. The maximum range for PVS-7 is only 300m. 3X magnifier can be used.

7. Fire the AT-4 using PVS-7 and PAQ-4C

Procedure. Mount PAQ-4C to AT-4 using field expedient means. Do NOT attempt to align head with sights. Acquire target using PVS-7. Activate PAQ-4C beam. Adjust PAQ-4C spot onto target. Pull trigger.

Techniques

- Boresighting. AT-4 expedient mounting cannot be boresighted.
- Illumination. Set up AT-4 in the dark. Remove PVS-7. Normal AT-4 sights can be used if target area is illuminated immediately before firing.

Common Errors

- Using the PAQ-4 in continuous mode. Do NOT 'search' the battlefield. Use the PAQ-4 beam only when engaging targets. Unit leaders, using lasers to direct fire, need to limit their men's use of individual weapons laser pointers.
- Mistaking another Marine's PAQ-4C beam for your own.
- Attempting to use the sights. Sights have absolutely NO effect on PAQ-4C accuracy.
- Firing without PAQ-4C. PVS-7, used without a PAQ-4C, does allow the shooter to set up weapon and acquire targets but shooter cannot use sight and PVS-7 does not improve AT-4 accuracy.

8. Fire the M-9 using PVS-7

Procedure. Focus PVS-7 on target. Do NOT attempt to align head with sights. Acquire target using PVS-7. Align body so PVS-7 vision parallels weapon direction. Focus 'over the sights.' Pull trigger.

Techniques

Common Errors

9. Read a map with PVS-7

Procedure. Lay the map on a flat, stationary surface. Holding head and goggles steady at a fixed distance, focus goggles on map. (20) centimeters is minimum focus range. Use a finger or pencil to maintain position on map when scanning remainder of map or looking at other objects.

Techniques. Tape all overlays to map to minimize moving parts. Fold map to minimize searching and folding in the dark. Use a second Marine to read notes or sketches, write notes, or talk on the radio.

Common Errors

- Attempting to read the map 'off-hand'. Movement of hand and head makes focusing impossible.
- Task overload. Due to fixed-distance focus and limited field of view, maintain the NVG on one item. Have a second Marine focus on other tasks.

10. Navigate with PVS-7

Procedures

- Ded Reckoning. Hold compass steady against body. Adjust NVGs to read dial. Look up and adjust NVGs to distant steering mark. Walk.
- Terrain-Association. Adjust NVGs to infinity. While moving, observe terrain, and follow preplanned route. Realize that many terrain features appear different or *not at all* on NVGs.

Techniques

- Maintain focus on distant terrain. Do not attempt to continuously refocus NVGs on ground or vegetation. When stopping to read map, see TTP 8., above.
- While moving, binoculars can also be used to improve distant night viewing.
- Realize that sense of hearing, smell, and touch is decreased due to concentration required for NVGs.
- The Lensatic Compass has luminous markings. Silva-type compasses are difficult to read with NVGs.
- Realize that depth perception is poor when using PVS-7. Experience with PVS-7 *increases* ability to perceive depth.

Common Errors

- Overconfidence. NVGs do not turn night into day. Good route planning is still a necessity.
- Tunnel vision. NVGs cut view from 188° to 40°. Scan continuously to make up for this limitation.
- Using the PVS-7 compass. This compass is off by approximately 15° due to metal in the mount. Use this compass for general orientation. Do not use this compass for taking azimuths while ded reckoning.
- Using the IR illuminator. In the 1982 Falklands War, British patrols could clearly observe Argentinean leaders moving at night with their NVG IR illuminators turned on.

11. Estimate Range using PVS-7

Procedure. Acquire target with PVS-7. Estimate range to target.

Techniques

- Use a map. Know your position. Look for identifying terrain features on the ground that can be found on the map. Have a second man look at the map to avoid refocusing between the map and the ground.
- Use a Laser Pointer to mark target for another Marine on PVS-7. Compare range estimates.
- Realize that depth perception is poor when using PVS-7. Experience with PVS-7 *increases* ability to perceive depth.

Common Errors

- Underestimation. At night, at ranges under 800m, Marines tend to *underestimate* range. If the terrain between the observer and his target is low ground, Marines tend to *underestimate* the range.
- Distant Target. The maximum range for PVS-7 is only 300m.

12. Call for Mortars, Artillery, and NSFS using PVS-7 to observe

Procedure. Focus PVS-7 to infinity. Use the bracket technique to get rounds on target. Realize that it is difficult to estimate

distance using the PVS-7 at night. HE rounds are clearly visible on PVS-7, sometimes the glowing shrapnel can be observed flying through the air.

Techniques

- Because PVS-7 reduces depth perception, use a map to help spot rounds. Determine distances by comparing surrounding terrain to the target. When a round splashes, try to plot its location on the map.
 - With PVS-7, white phosphorous mortar rounds work well for adjusting because the round is visible burning on the deck. For artillery, the M825 felt wedges look like burning red coals on the deck.
 - During high light level nights, M-22 binoculars can be used to measure mil deviation. Locate the round with PVS-7 and then quickly switch to the M-22 to measure deviation and estimate distance.
 - During low light level nights, M-22 binoculars cannot be used. The 'Hand Estimation Method' cannot be used with PVS-7 due to the requirement for rapidly focusing from far to near.
 - Realize that depth perception is poor when using PVS-7. Experience with PVS-7 *increases* ability to perceive depth.
 - A mil scale lens cap for the PVS-7 would allow observers to estimate left and right adjustments.
 - Using coordinated illumination allows the observer to operate in daylight conditions.
-
- Marking a target for aircraft is best done using M825 improved smoke. The felt wedges look like burning coals spread on the deck, and are clearly visible for minutes. The smoke screen may obscure the mark for non-IR equipped aircraft. WP has a bright flash, but subsides too quickly.

Common Errors

- Not realizing the depth perception limitations of the PVS-7.
- Not using the map to become familiar with the terrain around the target area.
- Not using PVS-7. Calling and adjusting at night is difficult to the unaided eye. HE produces a quick flash that is seen momentarily, if at all. WP produces an intense flash, but subsides quickly.

13. Acquire CAS aircraft using PVS-7

Procedure. Focus PVS-7 to infinity. Divide up the sky. Using a map for terrain association and the aircraft's final attack heading, sector off the airspace from which the aircraft will approach. Using all available eyes focused on this airspace, search for the 'moving star' with the aid of the PVS-7. Once the aircraft is acquired, padlock it. Do not look away.

Techniques. PVS-7 focused at infinity reduces the halo effect caused by the high luminance of the stars.

Common Errors

- Not looking in the right direction. Always use the map to sector off the sky.
- Tunnel vision. PVS-7s cut field of view from 188° to 40° . Scan continuously to compensate for reduced FOV.
- Losing sight of the aircraft. Once the aircraft is located, do not look away, or have a member of the TACP team watch the aircraft. This will save having to find the aircraft twice.
- Task saturation. One man spots and clears the aircraft to deliver ordinance. Assign someone to operate the laser pointer and any other distracting tasks.

14. Call for Close Air Support using PVS-7. See Hand-held Laser Pointer TTP.

15. Execute surveillance with PVS-7 and 3X Magnifier.

Procedure. Attach 3X to PVS-7. Focus on target area. Scan continuously.

Techniques. 3X makes goggles heavy. For long periods of surveillance, rest goggles on a flat surface. Narrow field of view requires constant movement to cover sector of observation. Binoculars can augment surveillance even at night. Relieve observers frequently.

Common Errors

- Overconfidence. 3X gives greater magnification, but at a cost of less light and less field of view. The image is darker and some targets are more difficult to identify.
- Obscuration. Any type of smoke or fog reduces the PVS-7s ability to see objects. This works to reduce the enemy's NVG capability as well.

16. Clear a room with PVS-7

Procedure. Flip up PVS-7 on Helmet Mount. Turn on white-light weapons-mounted flashlight. Allow eyes to adjust. Clear rooms and buildings using white light.

Techniques

- White light is recommended in MOUT. In buildings and restricted areas, the PVS-7 reduced field of view is a significant hazard. White light increases field of view, permits accurate target identification, and allows building lights to be used. Muzzle flashes, pyro, detonations, or cultural lighting does not blind Marines. Each Marine needs a weapons-mounted white-light flashlight.
- In large, open buildings such as hangars, use PVS-7 with IR illuminator on, augmented with IR illuminators. A weapons-mounted flashlight with an IR filter is recommended.
- When moving between buildings, PVS-7 should be used. From outside a building, IR weapons pointers can be used to illuminate inside darkened hallways, and open windows.

Common Errors. Attempting to clear rooms and buildings using the IR illuminator on PVS-7.

17. Pass Hand and Arm Signals using PVS-7

Procedure

Techniques

Common Errors

18. Navigate in an AAV using PVS-7

Procedure

Techniques. PVS-7 do NOT mount to the standard CVC helmet.

Common Errors

19. Navigate in a boat using PVS-7

Procedures

Techniques. PVS-7 have difficulty seeing IR chemlites mounted on engine housing rear. Using PVS-7 to take bearings for navigation is difficult due to range limitations.

Common Errors

20. Don PVS-7 while moving on foot

Procedure

Techniques

Common Errors

21. Establish a Pickup Zone using PVS-7

Procedure

Techniques

Common Errors

22. Operate PRC-119 with PVS-7

Procedure

Techniques. PRC-119 has illuminated control panel. Most radio tasks can be accomplished *without* NVGs.

Common Errors

23. Identify Enemy and Friendly Equipment using PVS-7

Procedure

Techniques

Common Errors

24. Install and Recover the M-18A1 Claymore using PVS-7

Procedure

Techniques

Common Errors

25. Wear Field Protective Mask with PVS-7

Procedure. Attach PVS-7 to Helmet Mount.

Techniques. Head Mount CANNOT be worn with field protective mask.

Common Errors

26. Ski with PVS-7

Procedure

Techniques

Common Errors

27. Conduct two-party cliff climb with PVS-7

Procedure

Techniques. *Extensive* practice is required to develop NVG climbing ability. Skill to re-focus PVS-7 between cliff face, hands, and equipment makes technique difficult to train large numbers of climbers.

Common Errors

28. Load ammunition with PVS-7

Procedure. Load M-16A2 magazine. Load M-249. Load M-240G.

Techniques. Marines must be trained to conduct immediate actions by feel in the dark. Refocusing PVS-7 onto the weapons is slow. Using the IR illuminator is dangerous.

Common Errors

29. Waterproof PVS-7

Procedure

Techniques

Common Errors

30. React to illumination with PVS-7

Procedure. Turn head. Close eyes. If goggles shut down, turn switch to OFF, then ON to reset.

Techniques

- If situation will not allow you to close both eyes, close one eye. Dark adaptation occurs independently in each eye.
- When firing a weapon, use short bursts to minimize muzzle flash and maintain dark adaptation.

Common Errors. Looking at illumination through goggles.

31. Use PVS-7 in the prone position

Procedure

Techniques. When wearing the flak jacket and lying in the prone, the PVS-7 on the helmet mount is pushed toward the ground, making it difficult to maintain visibility.

Common Errors

32. Fire the bangalore torpedo with PVS-7

Procedure

Techniques

Common Errors

33. Fastrope with PVS-7

Procedure

Techniques

Common Errors

34. Throw grenades with PVS-7

Procedure

Techniques

Common Errors

35. Signal with PVS-7 IR illuminator

Procedure. Turn goggles toward distant unit. Using IR switch, turn IR illuminator on and off to pass required signal. Observe distant unit for proper response.

Techniques

- Linkup procedures. Standard Operating Procedure should define linkup signal: "Moving unit initiates signal with four flashes. Stationary unit responds with two flashes."
- POSREP procedures. During SBF drill or other coordination drill, have distant unit signal: "Flash IR twice to confirm location."
- Signals should conform to standard usage. Two of anything is YES. Three of anything is DANGER.

Common Errors. Speed. Slow, deliberate signals are easier to see and recognize.

PVS-14

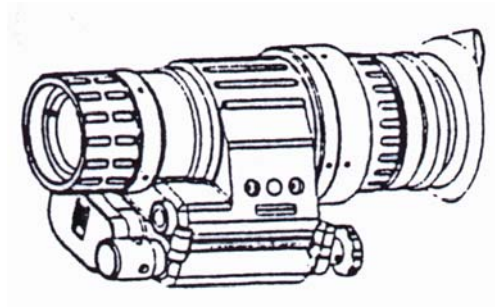

1. Nomenclature: AN/PVS-14 Monocular Night Vision Device

2. NSN: 5855-01-432-0524

3. Manual:

TM 10271A-10/1

TM 11-5855-306-10 *Operator's Manual, Monocular NVD, AN/PVS-14*, 30 Dec 1997

4. Description:

The PVS-14 allows the user to see at night using moonlight or starlight. The PVS-14 is a GEN III Image Intensification device similar in performance to PVS-7 NVGs, yet smaller, lighter, and more versatile. PVS-14s can be hand-held, carried in the utility uniform pocket, head-mounted, helmet-mounted, or mounted to a weapon.

5. Characteristics:

Weight: 14 oz

Focus Range: 25 cm to Infinity

Range: 150 m (Starlight), 300 m (Moonlight)

Battery: (2) AA

Battery Life: > 12 hours

Magnification: 1X

Diopter Adjustment: +2 to -6 diopters

Field of View: 40°

6. Accessories: Helmet mount, head mount, 3X Magnifier, and modular weapons mount.

7. Limitations:

In complete darkness, such as inside buildings, PVS-14s are ineffective unless additional IR illumination is present.

8. Usage Notes:

PVS-14s are intended for unit leaders and gunners. AA batteries are interchangeable with other equipment.

9. Supplier:

Marine Corps Issue. TAMCN: E1154 II BP. \$3607.00

ITT Night Vision, 7635 Plantation Road, Roanoke, VA 24019, (800) 533-5502, (540) 563-0371, FAX (540) 366-9015, <http://www.ittnv.com>

PVS-14 Training Handout

Ref: TM 10271A-10/1 *Operator's Manual, Monocular NVD, AN/PVS-14*, 30 Dec 1997

1. PVS-14 allows the user to see at night under moonlight or starlight.

2. Major components and their purposes.

PVS-14 have a (19)-item SL-3 Gear List. See Reference, pages 1-10 through 1-18.

- **Monocular** with Lens Cap to protect lens.
- **Demist Shield** for high humidity and rain. Degrades visual acuity.
- **Light Interference Filter (LIF)** to protect eyes from lasers.
- **Sacrificial Window** to protect monocular lens from dust and sand scratches.
- **Compass** to orient at night.
- **Tether Cord** is a dummy cord for compass or 3x Magnifier.
- **Head Mount & (3) Browpads** to mount monocular on head.
- **Helmet Mount** to mount monocular on helmet
- **Head / Helmet Mount Adapter** to attach monocular to mounts.
- **Small Arms Mount** to mount monocular to weapon.
- **Carrying Case & Strap** to carry monocular.
- **Storage Case** to store monocular and all accessories
- **Operator's Manual**

A **3x Magnifier Lens** is available as an optional accessory. See Reference.

4. Battery Installation. Either (2) AA Alkaline or (2) AA 1.5V DC Lithium

5. Indicator Lights

LOW BATTERY. Blinking red dot in eyepiece means less than 30 minutes of battery life.

IR beacon is ON. Steady red dot in eyepiece

6. Switch

OFF / RESET turns monocular OFF. Resets monocular after automatic shutoff.

ON turns monocular ON.

IR turns IR beacon ON. Pull and turn. A steady red dot appears.

7. Automatic Shutoff

The monocular shuts off automatically in excessive light, when monocular is removed from head mount, or when monocular is flipped up from the helmet mount. To turn monocular back on, turn switch to OFF / RESET, then back to ON.

8. Monocular Adjustment. PVS-14 have four (4) adjustments:

Variable Gain. Adjusts the brightness of the image. This reduces eyestrain, especially in changing light.

Objective Lens Focus. Adjusts for sharpest image of viewed object.

Diopter Adjustment Ring. Focuses eyepiece for sharpest image of intensifier screen. Rotate diopter adjustment ring for the clearest view of the image. If done in a lighted condition, line up the image through the goggle and the image in your naked eye.

Eye Relief. On Helmet and Head mounts, the distance between the user's eye and the monocular needs to be adjusted as close to the eye as is comfortable.

9. Maintenance

Clean lens with lens paper. Turn in for maintenance if monocular has shading, edge flow, flashing, flickering, or operates intermittently. Some blemishes or spots on screen are not deadline issues. Monocular can only be adjusted by higher echelon maintenance.

10. Mounts

Head Mount. Don Head Mount. Adjust straps. Attach Head / Helmet Mount Adapter to Monocular. Attach Monocular to Mount. Adjust Eye Relief by sliding mounting bracket toward or away from eyes.

Helmet Mount. Strap Helmet Mount to helmet. Attach Head / Helmet Mount Adapter to Monocular. Attach Monocular to Mount. Slide monocular up and down by loosening bracket knob. Adjust Eye Relief by sliding mounting bracket toward or away from eyes.

- Monocular can be flipped up when not in use.
- Monocular can be removed from the helmet by depressing the lever on the right side of the helmet

mount and removing the entire bracket.

- Monocular can be worn on either eye. Loosen the knob on the end of the Mount Adapter and rotate the monocular to the desired eye. Once the monocular is positioned, tighten the knob.

Small Arms Weapons Mount. Attach to weapon. Mount PVS-14 to mount. Can be used with 3X Magnifier.

11. Pre-Combat Checks

Install Batteries.

Remove Lens Cap. Install Sacrificial Window OR Compass OR 3X Magnifier.

Don and Adjust Head Mount OR Helmet Mount.

Make the four (4) monocular adjustments.

12. IR Beacon

IR beacon illuminates near objects in very dark conditions, or for signaling. The IR beacon CAN be detected by an enemy equipped with NVGs. Turn Beacon ON by pulling switch out and forward. A steady red dot appears in the eyepiece to signal the IR is ON.

PVS-14 TTP

See PVS-7 TTP. Most of the Tactics, Techniques, and Procedures for the PVS-7 are the same as for PVS-14. The following TTP are specific to PVS-14.

1. Fire the M-16A2 with PVS-14 mounted.

Procedure. Mount the PVS-14 to the weapon using the Small Arms Mount. Adjust PVS-14 far enough away from eye to prevent injury from weapon recoil. Op-check PAQ-4C / PEQ-2A beam by observing through PVS-14 monocular.

Techniques. Mounting PVS-14 to the M-16A2 is best done in stationary or defensive operations where the Marine is covering a sector from behind his weapon.

Common Errors

- Using a mounted PVS-14 during offensive actions. It is near impossible to use a mounted PVS-14 while moving with the weapon.
- Using the IR illuminator in a stationary position.

2. Fire the M40 Sniper Rifle with the Unertl scope and PVS-14.

Procedure. Mount the Unertl scope to the rifle. Cut a 7-inch piece of riggers tape lengthwise. Wrap it around the focus ring of the PVS-14, making sure you don't tape the focus ring to the body of the PVS-14. Turn the device on and focus at long range. Slide the focus ring into the ocular lens of the Unertl scope until it fits snugly. Readjust focus to ensure clarity.

Techniques. Small turns of the PVS-14 left and right will make focus adjustments.

Common Errors. Not adjusting proper eye relief for attaining good sight picture and avoiding scope bite.

3X Magnifier

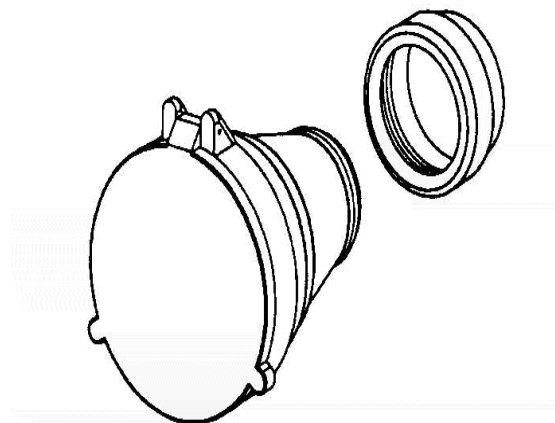

1. Nomenclature: 3X Magnifier

2. NSN: 5855-01-423-0817

3. Manual: NONE

4. Description:

The 3x Magnifier is an optional attachment to the PVS-7 and PVS-14. It is a small, lightweight, portable 3X lens that silently attaches to PVS-7 and PVS-14 without any tools. It is extremely helpful in surveillance.

5. Characteristics:

Weight: 190 g

Field of View: 11.6 degrees

Magnification: 3X

6. Accessories: Carrying Pouch with Alice clip.

7. Limitations:

Narrow field of view. Difficult to focus on near objects. Images appear darker due to less available light. 3X unbalances NVG mounts, causing neck strain.

8. Usage Notes: 3x are intended for unit leaders or Marines executing surveillance missions.

9. Supplier: Marine Corps Issue.

Section 2.2

Night Vision Scopes

PVS-4

PVS-4 Data Sheet
PVS-4 Training Handout
PVS-4 Tactics, Techniques and Procedures

PVS-17

PVS-17 Data Sheet
PVS-17 Training Handout (*TBD*)
PVS-17 Tactics, Techniques and Procedures (*TBD*)

PAS-13 TWS

PAS-13 Data Sheet
PAS-13 Training Handout (*TBD*)
PAS-13 Tactics, Techniques and Procedures (*TBD*)

PVS-4

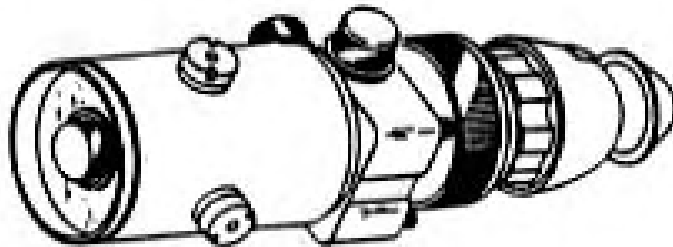

1. Nomenclature: AN/PVS-4 Night Vision Sight

2. NSN: 5855-01-629-5334

3. Manual:

TM 11-5855-213-10

Technical Manual, Operator's Maintenance Manual, Night Vision Sight, AN/PVS-4

1 Feb 1993, Change 1, 15 Jun 1993

4. Description:

The PVS-4 is an image intensifier weapons scope that allows the user to see in the dark under moonlight or starlight. A rubber cup prevents amplified light from illuminating the user.

5. Characteristics:

Weight: 3.9 lbs
Focus Range: 7 m to Infinity
Range: 400 m (Starlight), 600 m (Moonlight)
Battery: (2) AA or BA-5567/U Lithium
Field of View: 15 degrees
Magnification: 3.8X
Diopter Adjustment: -5 to +4 Diopters

6. Accessories:

Mounts and reticle patterns are available for M-16, M-203, M-249, M-60, and M7-2.

7. Limitations:

PVS-4 are difficult to use during movement, and are primarily used for target acquisition. The scope is bulky, makes a weapon extremely top-heavy when mounted, and is easily caught in vegetation. It has a tendency to cause "white-out" to the vision of the firing marine when used with machineguns.

8. Usage Notes:

The sight does not emit any visible or IR light. Marine Corps recommendation is to mount the PVS-4 on the M-203 of fire team leaders. A 25mm Gen III image intensifier tube is being retrofitted to upgrade current PVS-4s. PVS-4s will be replaced by PVS-17.

9. Supplier: Marine Corps Issue.

PVS-4 Training Handout

Ref: TM 11-5855-213-10

1. PVS-4

The **PVS-4 Night Vision Sight** is an image intensifier weapons scope that allows the user to see in the dark under moonlight or starlight.

2. Major components and their purposes

PVS-4 have a (12)-item SL-3 Gear List. See reference, pages B-4 through B-8.

- Daylight Cover for zeroing and daylight operation.

- Mounting Knob to fix bracket on the weapon system.
- Mounting Bracket to install scope on the weapon.
- Carrying Case to store scope and accessories.
- Carrying Bag to carry scope.
- AA Battery Adapter to allow the use of AA batteries.
- Operator's Manual

Older PVS-4s have two battery ports.

3. Battery Installation

Turn both switches off. Install batteries in adapter housing by observing the polarities marked on the housing.

4. Switches

ON / OFF Tube Brightness Turns on image intensifier, adjusts brightness of image.

ON / OFF Reticle Brightness Turns on the reticle, adjust reticle intensity.

5. Operation

Turn PVS-4 on. Adjust objective focus ring until distant image in scope is clear.

Turn reticle on and adjust intensity so that reticle is just visible against the background. Adjust diopter focus ring until reticle pattern is clear. Re-focus objective focus ring.

6. Maintenance

Use lens paper to clean the lens. Use an AP brush with CLP to clean the mounting rail.

7. Pre-Combat Checks

Before operating PVS-4, conduct inventory and check for cleanliness and serviceability.

While operating PVS-4, intensifier should be green and reticle pattern should be sharp.

PVS-4 TTP

1. Mount PVS-4 to M-16A2

Procedure

Techniques

Common Errors

2. Boresight PVS-4 to M-16A2

Procedure

Techniques

Common Errors

3. Fire M-16A2 with PVS-4

Procedure

Techniques

If PAQ-4C is mounted to weapon, do NOT boresight PVS-4. Observe PAQ-4C beam through PVS-4 scope, ignore PVS-4 reticle. Rounds will impact on PAQ-4C beam, regardless of iron sights, regardless of PVS-4 reticle.

Common Errors

4. Mount PVS-4 to M-203

Procedure

Techniques

Common Errors

5. Fire M-203 with PVS-4

Procedure

Techniques

Common Errors

6. Mount PVS-4 to M-249

Procedure

Techniques

Common Errors

7. Boresight PVS-4 to M-249

Procedure

Techniques

Common Errors

8. Fire M-249 with PVS-4

Procedure

Techniques

Common Errors

9. Mount PVS-4 to M-240G

Procedure

Techniques

Common Errors

10. Boresight PVS-4 to M-240G

Procedure

Techniques

Common Errors

11. Fire M-240G with PVS-4

Procedure

Techniques

Common Errors

12. Mount PVS-4 to Mk153 SMAW

Procedure

Techniques

Common Errors

13. Boresight PVS-4 to Mk153 SMAW

Procedure

Techniques

Common Errors

14. Fire Mk153 SMAW with PVS-4

Procedure

Techniques

Common Errors

15. Use PVS-4 reticles to estimate distance

Procedure

Techniques

Common Errors

PVS-17

1. Nomenclature: AN/PVS-17 Mini Night Vision Sight

2. NSN: 5855-01-459-4340

3. Manual: TBD

4. Description:

The PVS-17 is a lightweight, compact high-performance device that will use the OMNI GEN IV image intensifier tube. The system weighs less than two pounds, comes with the MIL-STD-1913 rail grabber interface, and is submersible to 66 feet. The PVS-17 can be mounted to any weapon that use the standard MIL-STD-1913 rail and will replace the PVS-4 in select units.

5. Characteristics:

Weight: 1.9 lbs

Range: TBD

Battery: (1) AA

Magnification: 4.5X

Field of View: 17-degree vertical, 20-degree horizontal

Water resistance: Submersible to 66 feet

6. Accessories: TBD

7. Limitations: TBD

8. Usage Notes:

The PVS-17 meets and exceeds the operational requirement of the PVS-4. It is designed to provide night fighting capability for individual direct fire weapons. Marine Corps recommended distribution is to fire team leaders.

9. Supplier: Marine Corps Future Issue. TAMCN: E1160 VIIGP. \$4,500.00

PAS-13

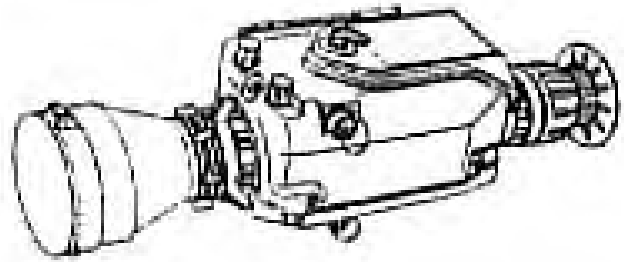
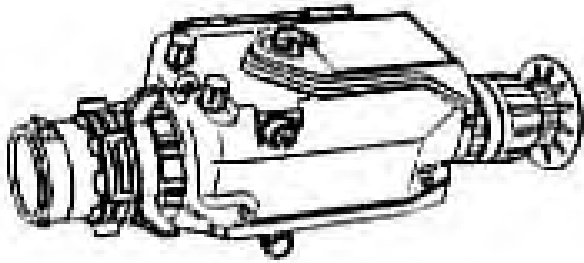

1. Nomenclature:

AN/PAS-13B Thermal Weapon Sight (TWS) v2 Medium
AN/PAS-13B Thermal Weapon Sight (TWS) v3 Heavy

2. NSN:

5855-01-464-3152 (v2 Medium)
5855-01-464-3151 (v3 Heavy)

3. Manual:

TM 10091A/100092A-10/1 Draft
TM 10091A/100092A-23&P2 Draft

4. Description:

The PAS-13 TWS is an IR imaging device that is passive, lightweight, modular, and battery powered. The difference between the medium and heavy models is the attached telescope. The PAS-13 TWS will mount on the MIL-STD-1913 rail.

5. Characteristics:

v2 Medium Weight: 5 lbs
v2 Medium Range: 1100 m (Clear), 300 m (Obscured)
v3 Heavy Weight: 6 lbs
v3 Heavy Range: 2000 m (Clear), 500 m (Obscured)
Battery: BA 5874 / U Batteries
Battery Life: > 12 hours

6. Accessories: Interchangeable lens

7. Limitations: The laser spots of hand-held and weapons laser pointers cannot be seen by PAS-13 TWS.

8. Usage Notes:

The PAS-13 TWS significantly enhances the Marine Corps' day and night fighting capability. The system can see through obscurants that impair systems operating in the visible and near-visible spectrum. The PAS-13 TWS has the ability to acquire targets under most conditions at maximum effective range of the weapon. PAS-13 TWS (v2 Medium) will be mounted to the M-249. PAS-13 TWS (v3 Medium) will be mounted to the M-240G, Mk19, and M2HB. Fielding for v2 is planned for FY 02, and v3 for FY 03.

9. Supplier:

Marine Corps Future Issue.

TAMCN: E1975 VII GP (v2 Medium) \$15,700.00

TAMCN: E1976 VII GP (v3 Heavy) \$17,200.00

Section 2.3

Weapons Laser Pointers

PAQ-4C

PAQ-4C Data Sheet
PAQ-4C Training Handout
How to Prepare for PAQ-4C Boresighting
How to Dry-Fire Boresight PAQ-4C to M16-A2
How to Live-Fire Boresight PAQ-4C to M16-A2

How to Boresight PAQ-4C to M-203 *(TBD)*
How to Boresight PAQ-4C to M-249 *(TBD)*
How to Boresight PAQ-4C to M-240G *(TBD)*
How to Boresight PAQ-4C to Mk 153 SMAW *(TBD)*

PAQ-4C Tactics, Techniques and Procedures

PEQ-2A

PEQ-2A Data Sheet
PEQ-2A Training Handout *(TBD)*
How to Boresight PEQ-2A to M-16A2 *(TBD)*
PEQ-2A Tactics, Techniques and Procedures *(TBD)*

PAQ-4C

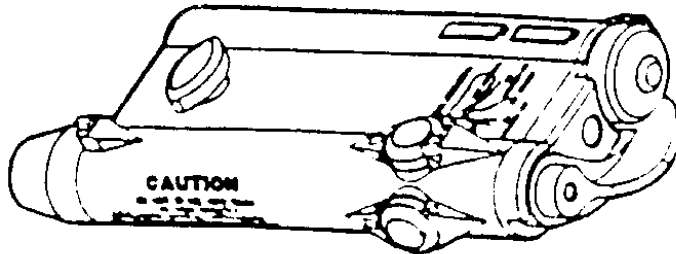

1. **Nomenclature:** AN/PAQ-4C Infrared Aiming Light

2. **NSN:** 5855-01-398-4315

3. Manual:

TM 09596C-12&P/1A *Technical Manual, Operator's and Unit Maintenance Manual (Including Repair Parts and Special Tools List), Light, Aiming, Infrared, AN/PAQ-4B, AN/PAQ-4C*

4. Description:

The PAQ-4C is a lightweight, battery operated, IR laser pointer aiming light that projects a continuous IR beam along the weapon's line of sight, designating the point of impact for Marines equipped with NVGs.

5. Characteristics:

Weight: 164 g / 5.8 oz

Size: 14 x 6.5 x 3 cm

Wavelength: 830 nm

Laser Class: 1

Power Output: 0.7 mW

Beam Width: 0.3 mR

Range: 600+ m (Depending on NVGs used)

Battery: (2) AA

Battery Life: 100 Hours

6. Accessories: Carrying bag, boresight filter, remote cable switch.

7. Limitations:

Currently, can only be mounted on M-16A2 and M-203. Other mounts are not yet fielded.

8. Usage Notes:

Can be used in hand-held mode by leaders issuing fire commands. Can illuminate indoors. PAQ-4C beam can be seen by low-flying RWCAS.

9. Supplier:

Marine Corps Issue. TAMCN: E0955 VIIB. \$400.00

Insight Technology, Inc., 3 Technology Drive, Londonderry, NH 03053, (603) 626-4800, FAX (603) 626-4888

PAQ-4C Training Handout

Ref: TM 09596C-12&P/1A

1. PAQ-4C

The PAQ-4C is a lightweight, battery operated, IR laser pointer aiming light that projects a continuous

IR beam along the weapon's line of sight, designating the point of impact for Marines equipped with NVGs.

2. Major components and their purposes

Boresight filter / diffuser minimizes laser bloom during zeroing.

Mounting Rail is permanently fixed to weapon in order to allow PAQ-4C to be attached.

Socket connects cable switch to PAQ-4C.

Cable Switch (optional) provides remote operation of the aiming light.

Cable Hanger (optional) is used to secure cable to weapon.

Adjusters are used to boresight PAQ-4C to the weapon.

Optical Baffle reduces off-axis detection of the aiming light.

Retaining Strap retains the battery cap.

ON / OFF Switch turns the PAQ-4C on and off.

Shroud protects the switch lever from accidental activation.

Thumbscrew Assembly secures the PAQ-4C to the mounting rail.

Battery Cap seals the battery compartment.

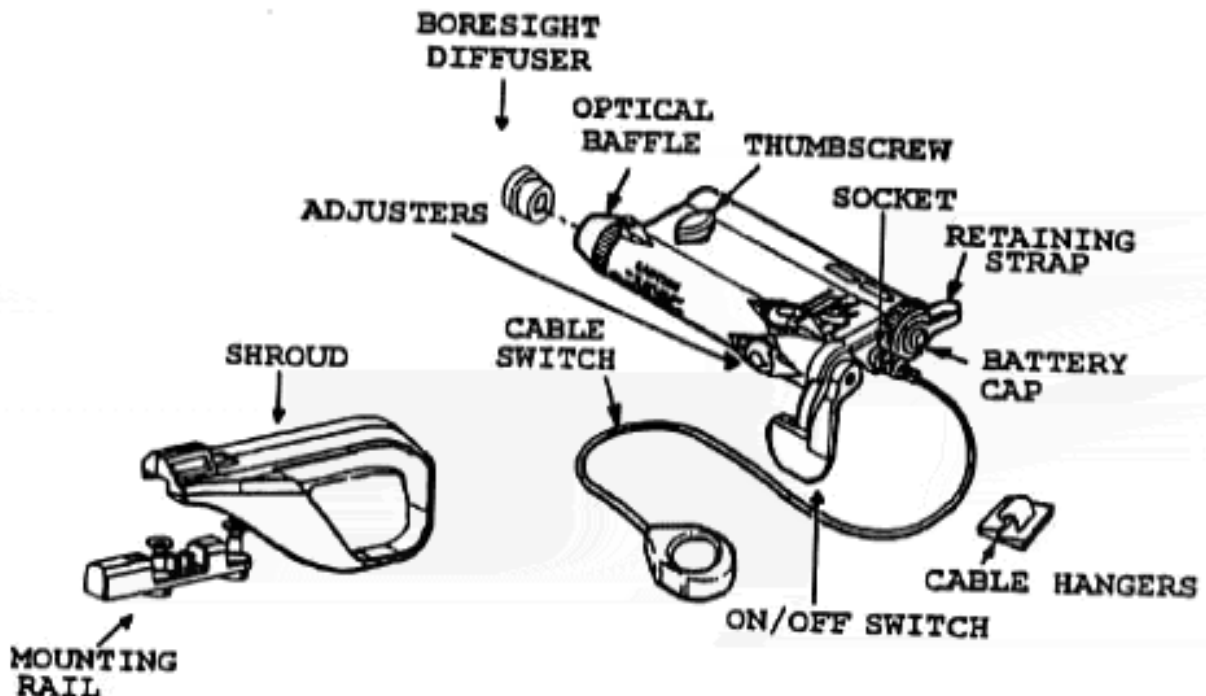

3. Battery Installation. Batteries are inserted with the positive ends (tips) up.

4. Maintenance

Use lens paper to clean the aiming light lens. Use AP brush with CLP to clean the mounting rail. Use damp cloth to clean aiming light unit.

5. Adjusters

The top adjuster moves the strike of the round right or left. A clockwise turn move the round left, a counter-clockwise turn moves it right. The side adjuster moves the strike of the round up or down. A clockwise turn moves the round up, a counter-clockwise turn moves the round down. Once the PAQ-4C is boresighted, do not reset the adjusters.

6. Pre-combat checks

Install the batteries.

Mount the PAQ-4C to the weapon.

Don NVGs. Conduct pre-combat checks for NVGs.

Activate PAQ-4C IR beam.

Point beam at feet and check beam with NVGs.

7. Mounts

When the mounting rail is initially attached to the M-16A2, coat the inside with CLP. Once the aiming light has been boresighted, the mounting rail cannot be removed. Rust then accumulates where the mounting rail touches the barrel. Use of CLP when attaching the mounting rail helps alleviate this problem.

The PAQ-4C cannot be mounted to the M-16A2 simultaneously with a MILES rifle transmitter.

The Marine Corps has purchased PAQ-4C mounts for the M-203. Units should order these mounts for all M-203. No boresight procedure has been published.

How to Prepare for PAQ-4C Boresighting

1. Prepare the target. Use a modified Marine Corps 30m BZO target for PAQ-4C boresighting.

Use the tan side of a cardboard E-silhouette target and stripe it with (3/4) inch black electrical tape so that the target is divided in half horizontally and vertically.

Center and staple the modified 30m BZO target to the silhouette.

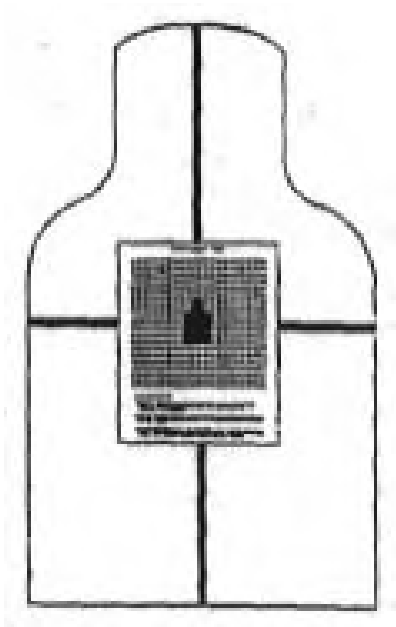

2. Prepare a shot-group transparency

Construct a transparency to use during both live-fire and dry-fire boresighting. This transparency will identify the center of the shot-group, since the shot-group will be offset from the center of the target at 30 meters.

Place a blank transparency over a modified 30m BZO target. Using a non-erasable black marker, draw one horizontal and one vertical line intersecting at the target's center point.

Place a mark (2.5) cm to the right and (3.5) cm above the center point. Draw a (5.5) cm circle around this mark. This circle is the desired location of the shot-group at 30 meters.

How to Dry-Fire Boresight PAQ-4C to M-16A2

1. Notes

This procedure works best in lighted conditions, outdoors or indoors. The Dry-Fire Boresight procedure requires that the weapon have a good 300m BZO.

2. Required gear

Modified 30m BZO target. *See How to Prepare for PAQ-4C Boresighting.*

M-16A2 with PAQ-4C mount

PAQ-4C with accessories

NVGs

Prepared shot-group transparency. *See How to Prepare for PAQ-4C Boresighting.*

Tape or stapler

Pack or sandbag

30m range

3. Required personnel. Three: *Shooter*, *Spotter*, and *Adjuster*. All wear NVGs.

4. Dry-fire boresight procedure

The *Spotter* sets a modified 30m BZO target 30 meters downrange.

The *Spotter* fastens the shot-group transparency to the BZO target such that the zero lines of the transparency line up with the zero lines of the BZO target and the marked shot group circle is low and to the left of the target. ***Warning. Do not look at the IR beam.***

The *Shooter* attaches the boresight filter to the PAQ-4C and sets the adjuster knobs to their neutral positions.

From a supported-prone position, using sandbag or pack, the *Shooter* aims at the center of the BZO target using the iron sights and then activates the PAQ-4C beam.

The *Spotter* observes the impact of the infrared beam, and calls adjustments until the beam impacts on the mark (2.5) cm to the left and (3.5) cm below the center of the BZO target.

The *Adjuster* listens to the calls from the *Spotter* and makes the appropriate adjustments while the *Shooter* maintains his position.

- Left / Right adjustments during dry fire are the opposite of live fire: Clockwise turns move the beam right, counter-clockwise turns move the beam left.
- Up / Down adjustments during dry fire are the opposite of live fire: Clockwise turns move the beam down, counter-clockwise turns move the beam up.

Repeat this process until the infrared beam impacts in the center of the circle on the prepared shot-group transparency.

Once boresight adjustments have been made, do not reset the adjusters. Once boresighted, the PAQ-4C can be removed from the M-16A2 and then put back on without losing the boresight. You must re-boresight if you remove the mounting rail.

How to Live-Fire Boresight PAQ-4C to M-16A2

1. Notes

This procedure generates a 300m boresight. It is recommended that a dry-fire boresight be conducted

prior to the live-fire procedure. The shooter will face difficulty acquiring the target due to a phenomenon known as *blooming*. See *PAQ-4C TTP*. Using tracer rounds simplifies the live-fire boresight procedure.

2. Required gear

Modified 30m BZO target. See *How to Prepare for PAQ-4C Boresighting*.

M-16A2 with PAQ-4C mount

PAQ-4C with accessories

NVGs

Prepared shot-group transparency. See *How to Prepare for PAQ-4C Boresighting*.

(14) rounds of ammunition

Tape or stapler

Mechanical pencil

Pack or sandbag

Flashlight

30m live-fire range

3. Required Personnel. Three: *Shooter*, *Spotter*, and *Adjuster*. All wear NVGs.

4. Live-fire boresight procedure

The *Spotter* sets a modified 30m BZO target 30 meters downrange.

The *Shooter* attaches the boresight filter to the PAQ-4C and sets the adjuster knobs to their neutral positions. Do *not* reset adjuster knobs if dry-fire boresight was previously done.

From a supported-prone position, using sandbag or pack, the *Shooter* activates the PAQ-4C beam, and places it on the center of the BZO target. A flashlight can be used if the target is difficult to see.

The *Shooter* fires a 3-shot group.

The *Spotter* goes down range and lines up the shot-group transparency with center of target, such that the marked shot-group circle is high and to the right of the target. He then calls back adjustments to move the shot group into the marked circle. He writes these adjustments in the upper left-hand corner of the target.

The *Adjuster* makes adjustments to the PAQ-4C while the *Shooter* maintains his position. The muzzle of the weapon is elevated.

- Left / Right adjustments: clockwise turns move the shots left, counter-clockwise turns move the shots right.
- Up / Down adjustments: clockwise turns move the shots up, counter-clockwise turns move the shots down.

The *Spotter* returns to the firing line.

Complete steps (c) through (g) two more times or until the shot group is inside the marked shot group circle.

The *Shooter* fires a 5-shot group to confirm accurate boresight.

The *Shooter* takes the 30m BZO target and records the final boresight adjustment numbers and keeps these in the buttstock of the weapon.

If a dry-fire boresight was done prior to the live-fire boresight, both adjustments must be combined and recorded as the final boresight.

Once boresight adjustments have been made, do not reset the adjusters. Once boresighted, the PAQ-4C can be removed from the M-16A2 and then put back on without losing the boresight. You must re-boresight if you remove the mounting rail.

PAQ-4C TTP

1. Fire weapons at night with the PAQ-4C

Procedure. Identify target through NVGs. Activate PAQ-4C. Move IR beam on to target. Fire weapon.

Techniques

- Do not leave beam on continuously. Do not search battlefield for target with IR beam activated.
- If having trouble distinguishing your own beam, make a "figure eight" to identify beam.
- Place buttstock of weapon snugly against shoulder. Grip weapon firmly to keep PAQ-4C beam steady. Ignore iron sights, ignore stock weld. Focus NVGs on PAQ-4C beam.
- Shoot low. Marines have a tendency to shoot high in the dark.
- Left-handed shooters can shoot right-handed with PAQ-4C because weapon posture is less important.

Common Errors

- Too many PAQ-4C beams on continuously.
- Inability to clearly distinguish target. PAQ-4C does not "light up" target for identification.
- Trying to achieve stock weld.
- Adjusting the iron sights. Weapons sights have no impact on PAQ-4C accuracy.

Note. See Section 2.1 PVS-7 TTP for the following weapons techniques:

Fire the M-16A2 with PVS-7 and PAQ-4C
Fire the M-203 with the PVS-7 and PAQ-4C
Fire the M-249 with PVS-7 and PAQ-4C
Fire the M-240G with PVS-7 and PAQ-4C
Fire the Mk153 SMAW with PVS-7 and PAQ-4C

2. Overcome PAQ-4C "blooming" phenomenon

Procedure. Blooming is when a point of light strikes a target at short range and is reflected back to the shooter's goggles. This makes it difficult to see shapes and lines clearly.

Techniques

- For boresighting, use a modified 30m BZO target. Use the boresight diffuser. *See How to Prepare for PAQ-4C Boresighting.*
- For live targets, move PAQ-4C beam around until you can see a clear outline of the target before engaging. Insure that NVGs are focused correctly. *See Section 2.1.*

Common Errors

- Impatience.
- Incorrectly focused NVGs.

3. Use PAQ-4C to control organic fire

Procedure. Mark the target by placing PAQ-4C beam on it and making a figure eight. This is called a 'Snake.' Issue fire command. Marines confirm target: "I see it!"

Techniques

- Fire all tracer rounds to identify target for those Marines without NVGs.
- Unit leaders can use PAQ-4C in hand-held mode. Use PAQ-4C to point out terrain features, routes, enemy positions, or sectors of fire.
- When the engagement calls for surprise fire, such as an ambush, each Marine can verify his target before firing by placing a PAQ-4C beam on it. Unit leaders can then deconflict.

Common Errors

- Impatience. With the limited field of view of the NVGs, it may take a moment to spot the PAQ-4C beam. Keep the beam active and moving on the objective until your men signal, "I see it!"
- Too many targets. The difficulties in identifying targets, combined with the difficulties of hitting targets, should convince leaders of squad-sized units to engage one target at a time.
- Too many PAQ-4C beams. PAQ-4Cs should only be used when engaging targets. When a unit leader is issuing fire commands, other Marines should keep their PAQ-4Cs off to minimize confusion.

Note. Many PAQ-4C techniques are the same for Hand-held Laser Pointers. *See Section 2.4.*

4. Illuminate inside buildings with PAQ-4C

Procedure. In dark areas, such as inside building, NVGs need an additional light source, even beyond the IR spot. Use the PAQ-4C beam as a very low power flashlight to illuminate corridors and rooms with IR light.

Techniques

- Point the PAQ-4C beam across the street into open windows to illuminate a room. The amount of illumination depends on the reflectivity of the wall surface.
- Use white light flashlights mounted on weapons. Do not use NVGs. The recommended technique for night fighting inside buildings is to use white light. *See Section 2.9.*

Common Errors

- Overconfidence. IR light is better than none, but it is still limited. NVGs restrict field of view. Teams have difficulty moving, illuminating and searching with these limitations.
- Mixed units. If every man does not have NVGs, PAQ-4C illumination is not the answer. Leave those without NVGs outside the building or switch to white light.

5. Boresight the PAQ-4C to the Mk153 SMAW

Procedure. During dusk. With a target at the desired boresight distance. Remove the Mk153 SMAW telescopic sight. Attach the PAQ-4C to the Mk153 SMAW railing inverted and screwed on, ensuring that the PAQ-4C can move somewhat freely to make adjustments. The ammo man dons NVGs and mounts a 3X magnifier. The gunner sights in on the target using the Mk153 iron sights. The ammo man triggers the PAQ-4C, observes the beam with his NVGs, and adjusts the beam onto the target. When the PAQ-4C beam is on target, the ammunition man turns the screw to secure it tightly.

Techniques

- Once the PAQ-4C is boresighted to the Mk153 SMAW, the gunner ignores the iron sights, dons NVGs and a 3X magnifier, and prepares to engage using only the PAQ-4C beam.
- PVS-14 are better than PVS-7 for SMAW gunners.
- Spotter rounds should not be used.

Common Errors

PEQ-2A

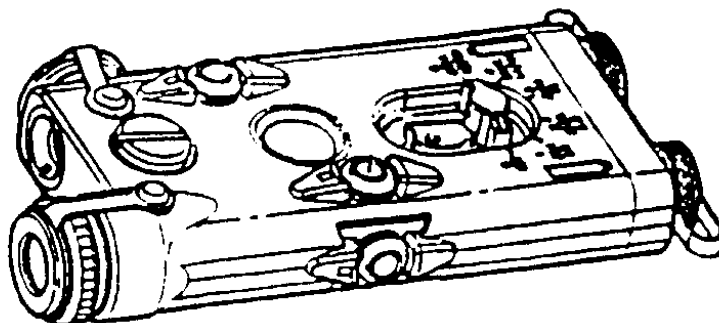

1. Nomenclature: AN/PEQ-2 Aiming Light, Target Pointer, Illuminator, Infrared

2. NSN: 5855-01-422-5253

3. Manual:

TM 10470A-12&P/1 *Operator and Unit Maintenance Manual Including Repair Parts and Special Tools List*

5. Description:

The PEQ-2A is a weapons aiming light, target pointer, and illuminator. It emits separate aiming and illuminating beams, with the capability of centering the aiming beam within the illumination area. It is designed primarily to provide infantry leaders an IR searchlight with an integral aimpoint for accurate night firing. Secondary uses include searching for, and pointing out targets for fire commands.

5. Characteristics:

Weight: 7.5 oz
Wavelength: 830 nm
Laser Class: 3b
Power output, aiming beam: 25 mW
Power output, illuminator: 30 mW
Range: 1300 m
Battery: (2) AA
Battery Life: > 100 hours

6. Accessories: MIL-STD-1913 rail mount, carrying bag, remote cable switch, and boresight filter.

7. Limitations: Visible to an enemy with NVGs, especially in smoke, fog, and rain.

8. Usage Notes:

Illuminator beam can be used as IR flashlight, especially useful in MOUT. Controls allow aiming beam on or off, power high or low. Can be used in hand-held mode. 1300-meter range exceeds maximum ranges of current NVGs.

9. Supplier: Marine Corps Issue. TAMCN: E1798 VIIG. \$1000.00

Section 2.4

Hand-held Laser Pointers

PEQ-4

PEQ-4 Data Sheet
PEQ-4 Training Handout

LPL-30

LPL-30 Data Sheet
LPL-30 Training Handout

IZ-LID II

IZ-LID II Data Sheet
IZ-LID II Training Handout

GCP

GCP Data Sheet
GCP Training Handout (*TBD*)

Hand-held Laser Pointer Tactics, Techniques and Procedures

PEQ-4

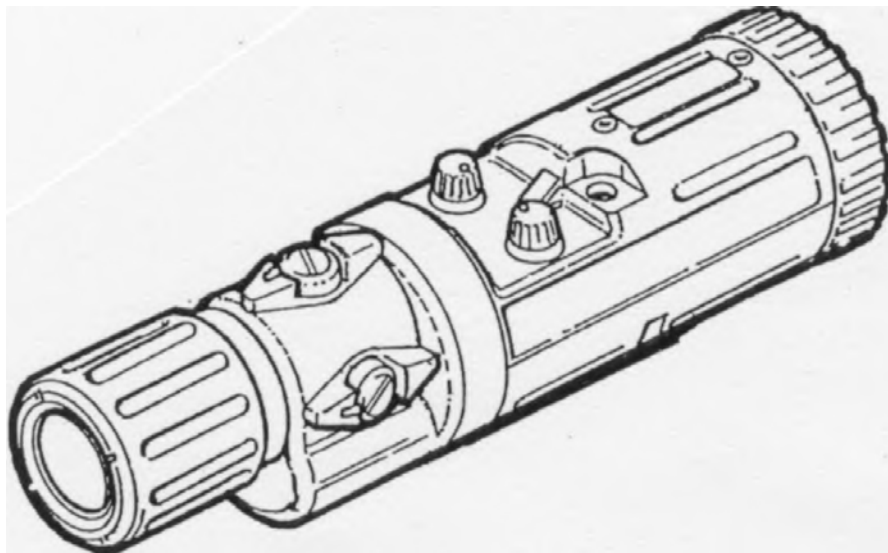

1. Nomenclature: AN/PEQ-4 Medium Power Laser Illuminator (MPLI)

2. NSN: 5855-01-460-8365

3. Manual:

TM 10580A-12&P/1 *Operator's Manual, Medium Power Laser Illuminator (MPLI), PEQ-4*

4. Description:

The PEQ-4 is a hand-held, battery operated, IR laser pointer, designed to illuminate and mark targets for night-vision capable aircraft and supporting arms.

5. Characteristics:

Weight: 12 oz

Size: 10 in x 3 in x 3 in

Wavelength: 850 - 870 nm

Beam Divergence: Min: 1 m at 1000 m (1 mrad), Max: 3 degrees

Power Output: Low: 100 mW, High: 600-800 mW

Laser Class: 4

Range: 2200 m, 10 km for aircraft

Battery: (6) AA or (3) DL 123 Lithium

6. Accessories: 24-inch Cable Switch.

7. Limitations: Visible to enemy with NVGs, especially in smoke, fog, and rain.

8. Usage Notes:

Marine Infantry Battalions rate (3) PEQ-4, one for each Air Officer and FAC. However, ground unit leaders and FOs have requirements to coordinate supporting fires with tanks, AAVs, TOWs, HMGs, and adjacent units, as well as aircraft.

9. Supplier:

Marine Corps Issue. TAMCN: E1799 VIIG. \$4000.00

Insight Technology, Inc., 3 Technology Drive, Londonderry, NH 03053

PEQ-4 Training Handout

Ref: TM 10580A-12&P/1 *Operator's Manual, Medium Power Laser Illuminator, PEQ-4*

1. PEQ-4

The PEQ-4 is a hand held, battery operated, IR laser pointer, designed to illuminate and mark targets for night-vision capable aircraft and supporting arms.

2. Major components and their purposes

PEQ-4 Assembly. The focus knob varies the beam from spot to flood. Rotate counterclockwise for maximum flood for area illumination. Rotate clockwise for minimum spot for target designation.

Attenuation Filter reduces laser to eyesafe level. Filter snaps onto the Solid Cover.

Solid Cover blocks IR light.

Carrying Bag holds all components and attaches to web belt.

Spare Battery Box is a replacement item.

ON/OFF Switch is a detachable switch for hand-held use.

Cable Switch is a detachable 24-inch cable switch for tripod or fixed mount use.

Hexkey installs the plug screws.

Plug Screws plug the mounting holes.

3. Battery Installation

Place both switches on OFF. Remove switches prior to installing batteries.

Unscrew the battery cap and install (3) DL 123 or (6) AA batteries. Orient the batteries as indicated by the markings on the case.

Install battery box with arrow pointing toward contact button.

Do not store the PEQ-4 with batteries installed.

4. Operation

Cable Switch. A 24-inch cable switch plugs into the remote jack on the PEQ-4. When the cable switch is installed, it locks in place. To remove the cable switch, pull back on the plug sleeve and pull the plug out. Do NOT pull the cable.

Switches. Two mode selector switches select power levels and pulse modes.

- (1) Switch 1 Selects OFF, LOW, MEDIUM, or HIGH power. Rotating the switch from OFF puts the laser in standby.
- (2) Switch 2 Selects OFF, three different pulse rates (2, 5, or 10 Hz) or the Steady On (CW) mode.

Switch 1	Switch 2	Operation	Remarks
OFF	OFF	Off	Normal storage co
LO, MED, HIGH	OFF	Standby	Green LED blinkir when Switch 2 is r pushbutton depres

OFF	2, 5, 10, CW	Standby	Green LED blinkir when Switch 1 is r pushbutton depress
LO, MED, HIGH	2, 5, 10	Pulsing On	Pulsing mode is us 4 laser from other
LO, MED, HIGH	CW	Steady On	Steady On mode is lasers are being us

5. Maintenance

No Special tools are required for maintenance. Clean the PEQ-4 with a soft damp cloth, especially after exposure to salt water. Use a soft clean cloth with clean water, alcohol, or window cleaner to clean the aiming and illumination beam windows.

6. Boresighting

The PEQ-4 has (2) adjusters for zeroing the laser beam when mounted. The top adjuster moves the beam vertically. A clockwise turn moves the beam down. The side adjuster moves the beam horizontally. A clockwise turn moves the beam right.

7. Safety

The PEQ-4 is a class 4 laser. It can burn paper and human skin, and cause massive damage to your eyes. Treat the PEQ-4 as a weapon. Never point it at anything you do not wish to destroy.

LPL-30

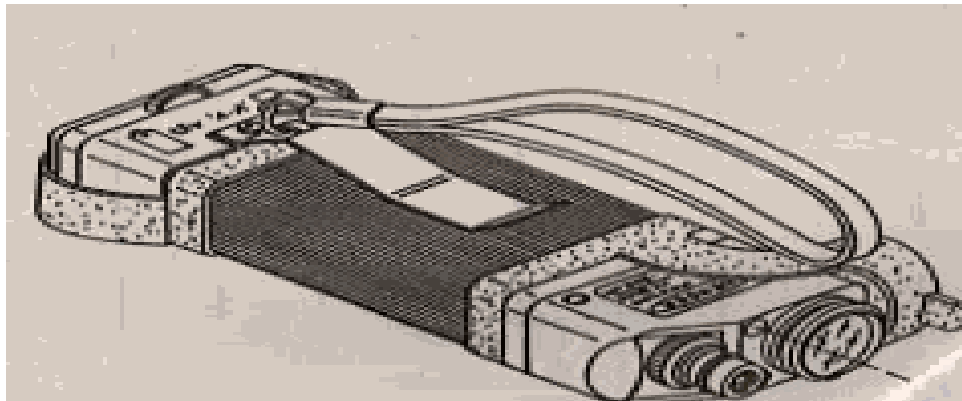

1. Nomenclature: LPL-30 Hand-held Medium Power Laser Pointer

2. NSN:

3. Manual: *LPL-30 Operator's Manual*

4. Description:

The LPL-30 is a lightweight, hand-held IR laser pointer, visible to Marines with NVGs. It is designed to mark targets for both aircraft and ground units.

5. Characteristics:

Weight: 195g
Size: 124mm x 40mm x 20mm
Wavelength: 800 - 870 nm
Beam divergence: 12 in at 1000 m
Power Output: 15 mW
Laser Class: 3b
Range: 4 km
Battery: (2) AA Battery Life: 5 to 10 hours

6. Accessories:

Soft carrying case
Beam diffuser / expander & holder
Deflector head
Training head

7. Limitations:

Fixed-wing aircraft at high altitude have difficulty seeing the narrow LPL-30 beam.

8. Usage Notes:

Some Marine units were issued LPL-30 as an interim hand-held laser pointer while awaiting fielding of the PEQ-4.

9. Supplier: International Technologies, Ltd. TAMCN: NONE.

LPL-30 Training Handout

Ref: *LPL-30 Operator's Manual*

1. LPL-30

The LPL-30 is a lightweight, hand-held IR laser pointer, visible to Marines with NVGs. It is designed to mark targets for both aircraft and ground units.

2. Major components and their purposes

Laser Transmitter includes laser head and electronics module.

Laser Beam Output Window is laser beam outlet, protected by rubber cover.

Battery Compartment accepts (2) AA batteries.

Operating Switch is a pushbutton trigger switch.

Operating Indicator Lamp indicates that the LPL-30 is operating and that the batteries are correctly inserted.

Rubber Sleeve protects LPL-30 from impacts and dirt.

Belt Clip to hang LPL-30 from belt.

Carrying Strap to carry LPL-30.

Carrying Case with carrying handle.

3. Battery Installation

Press battery compartment cover grips and pull out cover. Insert (2) AA batteries into battery compartment. Notice the polarity marking on the instrument body. Replace battery compartment cover by pressing the two grips and pushing cover into place. Remove the batteries from the LPL-30 prior to storage.

4. Operation

Press laser trigger. Using night vision device, bring laser beam onto target. To turn beam off, release trigger.

5. Maintenance

Laser beam output window. Check window for chips or cracks. Clean with damp cloth and dry with lens paper.

Exterior. Check for damage. Clean. Rinse with water after exposure to salt-water.

Batteries. Check for leaks. Replace faulty batteries.

Battery Compartment. Check for corrosion. Clean electrical contacts.

Operating Switch. Install batteries. Press and hold switch. Use NVGs to check operation.

Carrying Case. Use a damp cloth to clean.

6. Storage

Store the LPL-30 in a dark, cool, moisture-free area. Use of an anti-moisture agent such as Silica Gel is recommended. Avoid exposure to heat.

7. Optional Accessories

Soft carrying case for storage under field conditions.

Beam diffuser / expander diffuses the laser beam to use LPL-30 as an IR illuminator.

Beam diffuser holder holds diffuser when not in use.

Deflector head (Operations) deflects laser 90 degrees.

Deflector head (Training) deflects laser 90 degrees. Contains filter to make LPL-30 eyesafe. Training deflector is identical to operational deflector except for its blue color.

IZ-LID II

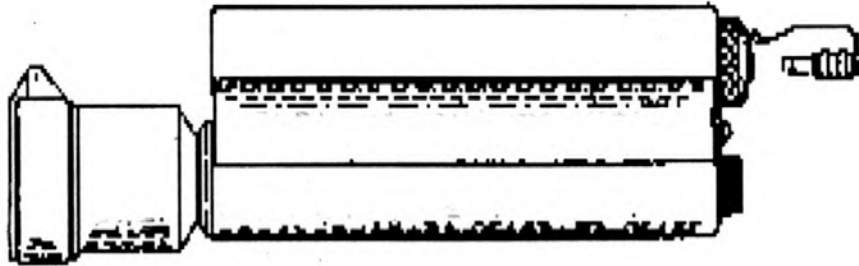

1. **Nomenclature:** IZ-LID II High Energy Infrared Zoom Laser Illuminator

2. **NSN:**

3. **Manual:** *IZ-LID II Operator's Manual*

4. Description:

The IZ-LID II is a high-power, hand-held, laser illuminator / designator visible to Marines with NVGs. It is designed to illuminate and mark targets for aircraft and supporting arms.

5. Characteristics:

Weight: 1 lb 11 oz

Length: 9.9 in

Wavelength: 870 nm

Beam Divergence: 1 m at 1000 m (1 mrad), 5 m at 5 km

Power Output: Laser output: 1 w

Optical lens: 525 mw

Laser Class: 3b

Range: > 5 km

Battery: (3) C

Battery Life: 1.5 hrs

6. Accessories: 2000mm F/11 telescope, Tripod mount

7. Limitations: Visible to an enemy with NVGs, especially in smoke, fog, or rain.

8. Usage Notes: Waterproof to 66 feet.

9. Supplier:

B.E. Meyers & Co. Inc., <http://www.bemeyers.com>, (800) 327-5648, (800) DARKNITE, FAX (425) 867-1759

IZ-LID II Training Handout

Ref: *IZ-LID II Operator's Manual*

1. IZ-LID II

IZ-LID II is a high-power, hand-held, laser illuminator / designator visible to Marines with NVGs. It is designed to illuminate and mark targets for aircraft and supporting arms.

2. Major components and their purposes

Aperture Cap prevents inadvertent laser emission.

ON / OFF LOW / HIGH Switch turns IZ-LID on. Selects laser pulse rate.

Battery Compartment accepts (3) C batteries.

Laser LED indicates low, medium, and high power modes.

Tethered Male Arming Plug arms laser when plugged into battery compartment.

C-mount Lens is the objective lens. Removal of lens increases unit to Class 4 laser.

Zoom Control adjusts beam convergence from spot to flood

3. Battery Installation

Unscrew battery cap. Insert (3) C cells with the positive button facing forward. Replace battery cap. Do not store batteries inside IZ-LID II.

4. Operation. At night, while wearing NVGs:

Flip up Aperture Cap.

Insert arming plug at center rear of battery compartment

Turn power switch counterclockwise to LOW, HIGH, or HIGH PULSE.

Turn Objective Lens counterclockwise for pinpoint beam or clockwise for flood beam.

5. Maintenance

The IZLID II is waterproof. Flush with fresh water after exposure to salt water. Dry completely before storage.

Clean the lens with dry lens paper or tissue paper.

GCP

1. Nomenclature: Ground Commander's Pointer (GCP): GCP-1A, GCP-1B, GCP-2, GCP-2A

2. NSN:

GCP-1A 5855-01-420-0849

GCP-1B 5855-01-420-0851

GCP-2 (v1) 5855-01-420-0817

GCP-2 (v2) 5855-01-448-8155

GCP-2A (v1) 5855-01-420-0821

GCP-2A (v2) 5855-01-448-8159

3. Manual:

4. Description:

The GCP is a family of hand-held laser pointers and illuminators, visible only to Marines with NVGs. GCP is designed to provide marking and illumination for ground commanders. The beam can be adjusted from spot to flood.

5. Characteristics:

Weight: GCP-1A, GCP-1B 128 g / 4.5 oz

Weight: GCP-2, GCP-2A 143 g / 5 oz

Wavelength: 830 nm

Beam Divergence: 0.5 mR to 30 degrees

Power Output: GCP-1A, GCP-2 50mW

Power Output: GCP-1B, GCP-2A 100 mW

Laser Class: 3b

Range: (Spot Beam / 2-degree Beam / 10-degree Beam)

GCP-1A: 8000 m / 1500 m / 800 m

GCP-1B: 12,000 m / 3000 m / 1600 m

GCP-2: 8000 m / 1500 m / 800 m

GCP-2A: 10,000 m / 3000 m / 1600 m

Battery: (2) AA

6. Accessories: Power switch safety cover, lens cover.

7. Limitations: Visible to enemy with NVGs, especially in smoke, fog and rain.

8. Usage Notes:

U.S. Army airborne and Ranger units down to squad level have been issued commercial GCPs for development of night techniques. GCP can mark targets for organic and non-organic ground fires and CAS. GCP can illuminate dark areas, provide ITG for helicopters, and point fields of fire. Can also be weapon-mounted.

9. Supplier:

Night Vision Equipment Corporation, Inc., P.O. Box 266, Emmaus, PA 18049-0266, POC: Gene Adcock, VP, (610) 391-9101, FAX (610) 391-9220, <http://www.nvec-night-vision.com>, nvec@ptdprolog.net, GCP-1A \$1051.00, GCP-1B, \$1451.00, GCP-2 \$1548.00, GCP-2A \$1851.00

Hand-held Laser Pointer TTP

Weapons laser pointers, PAQ-4C and PEQ-2A, either hand-held or mounted to a weapon, can also be used for most of the following TTP. The PAQ-4C can be seen by Cobras.

1. Mark your position at night with a Hand-held Laser Pointer

Procedure. ‘Rope’ your position by pointing the laser pointer to the sky and moving it in a circular manner like a lasso to form a cone of IR light.

Techniques

- ‘Rope’ can be a distant ITG signal for assault helicopters on extract, medevac, or resupply missions.
- ‘Rope’ can be a POSREP signal to orient adjacent and supporting units.
- ‘Rope’ can be a link-up point signal, especially with vehicles on medevac or resupply missions.
- ‘Rope’ marks friendly observer position for CAS aircraft.
- An alternate POSREP technique is to mark your position by running the IR beam from a circle at your feet out toward the target and then back to your feet, while communicating with the observer.
- In an urban area, the ‘rope’ can be made on the side of a building, while communicating your position relative to the building.

Common Errors

- ‘Roping an aircraft. Do NOT point a laser pointer anywhere near an aircraft.
- Stopping early. Maintain ‘rope’ until the other Marine sees your position.

2. Mark a target at night with a Hand-held Laser Pointer

Procedure: ‘Snake’ a target by placing the IR laser beam on the target and moving the beam in a figure-eight motion. ‘Steady’ the beam on the target by holding the pointer still. ‘Shift’ the beam from one target to another, keeping the beam turned on. ‘Stop’ the IR beam by shutting the beam off. ‘Stop’ is different from ‘Terminate,’ which is only used to cease illumination by a laser *designator*.

Techniques. Maintain 'snake' on the target until observer sees your mark. At that point you should 'steady' the mark, and keep it on the target throughout the attack.

- For CAS, the pilot will initiate most of the calls.
- For organic or supporting fires, such as tanks, AAVs, TWO, HMG or snipers, the unit leader requesting fire will make most of the calls.
- To mark a target in a well-lit urban area, first 'snake' a darkened area, have the pilot acquire the mark, and then slowly move the mark to the target.
- In an urban area, the 'snake' can be made on the side of a building, and then moved to the actual target, while communicating with the observer.

Common Errors.

- Excessive laser pointer movement. It is easier to see a moving spot than a stationary one. Too much movement, however, confuses the observer.
- Not using standard IR laser terminology as above.
- Stopping the beam before the mark has been seen by the attacking unit.
- Using the same pointer motion for both 'rope' and 'snake.'

3. Control CAS at night with a Hand-Held Laser Pointer

Procedure. Establish a laser-to-target-line (LTL) and determine the best aircraft attack direction. As the aircraft appear, rope your position until they contact the beam. Using PVS-7, acquire the aircraft and keep it in sight. This is imperative to give them a "cleared hot" call. When the pilot calls "snake," you will snake the target until he sees the mark and calls "contact the mark." The next call is "steady" as they begin their attack run. Keep the laser spot steady on the target throughout the aircraft's attack.

Techniques

- IR pointers work best in low light conditions. Higher light levels, especially cultural lighting, reduce the distance at which aircraft can pick up the IR beam.
- Round the magnetic heading of the LTL to the nearest five degrees. Give the aircrew a final attack cone (FAC) off one shoulder. Use a standard safety cone of 10 degrees on either side of the LTL to prohibit aircraft approach. The cone should be between 10 and 60 degrees off the LTL to provide good opportunity for the aircrew to "contact the mark."
- MAWTS-1 recommends a *combined* laser spot with tracer fire from 7.62 or .50 caliber machineguns.
- Locate friendly forces by marking positions on the deck while communicating with aircraft.
- Aircraft with laser pointers can confirm target location by marking target from the air and having observer acknowledge correct target.

Common Errors

- Excessive laser pointer movement. Use slow, deliberate movements.
- Not using a 10 to 60 degree final attack cone to give the aircrew the best chance to acquire the mark. If the aircraft is attacking from 90 degrees off the LTL, it will not see the laser mark. The aircraft should NEVER attack head-on toward the controller.
- Failure to use standard Joint CAS terminology.
- Failure of aircraft to contact the mark. Fixed-wing aircraft using high-altitude tactics may have difficulty acquiring the spot.
- Using a flood beam. Using a wide-angle beam shortens the range of the laser pointer and decreases the acquisition range of the aircraft, making it more difficult for the aircraft to see the mark.
- Confusing aircraft. Insure that marks on friendly forces are not confused with marks on target.
- Allowing an enemy with NVGs to see laser and locate friendly forces.

4. Control direct fire at night with a Hand-held Laser Pointer

Procedure. 'Rope' your position if necessary to orient distant firing units. 'Snake' the target, key terrain, friendly positions, and control measures to orient observers. 'Snake' the target to mark. Issue fire command. 'Steady' beam on target during attack. 'Shift' beam to shift fires to another target. 'Stop' beam and pass "cease fire."

Techniques

- Distribute fire by marking multiple targets and assigning each target to separate firing units. An engagement area (EA) can be defined by snaking each of the target reference points (TRPs) that define the EA.
- Concentrate fire by issuing the same fire command to multiple units while marking a single target.
- Small unit leaders can mount their Hand-held Laser Pointer to the top of their NVGs with tape for hands-free access.
- Small units can be issued verbal orientation and fire commands to match laser directions. Small unit leaders can move to each weapon for guidance and direction.
- Supporting units, such as tanks, AAVs, HMG, TOWs, anti-armor, and snipers, require radio communications. Extra care should be taken when orienting by laser and radio, and marking targets by laser and radio. The firing unit may be able to confirm targets by responding with their own laser mark.
- In defensive operations, a Hand-held Laser Pointer can be used to check the sectors of fire for each weapon. Weapons equipped with weapons laser pointers can confirm their sectors, targets, and shift targets.

Common Errors

- Poor fire distribution or concentration resulting from poorly communicated fire commands or misunderstood laser marks. Intermittent radio communication can cause dangerously misunderstood fire commands.
- Mistaking another laser beam for the leader's laser beam on an IR-cluttered battlefield. Unit leaders need to insure that individual weapons laser pointers are only used while firing.
- Not using standard laser terminology.

5. Execute support-by-fire (SBF) drill at night with a Hand-held Laser Pointer

Procedure. The commander of the SBF unit needs to kneel and execute the following procedure with each of his weapons crews. Gunners and leaders need NVGs. Using a Hand-held Laser Pointer, 'Snake' the objective, key terrain, and control measures to orient each crew. 'Snake' friendly positions and planned maneuver lanes. Define the left and right lateral limits. The crew records these azimuths. Define the primary target and the shift target. The crew records these azimuths. Issue fire commands.

Techniques

- If possible, friendly positions should signal the SBF position during the SBF drill to confirm their locations.
- The leftmost (or rightmost) weapon can fire tracers to define the target and shift target. All weapons equipped with night scopes or laser pointers should fire no tracers.
- Small unit leaders can mount their Hand-held Laser Pointer to the top of their NVGs with tape for hands-free access.
- The SBF drill is best done during the day. All targets and limits are laid on the guns when visible. Azimuths are recorded for backup. Even with NVGs and laser pointers, executing the SBF drill in the dark should be avoided.

Common Errors

- Not allowing enough time. Not only is the SBF drill more accurate if run during the day, it is also faster during the day. Running the SBF drill in the dark takes a significant amount of time *for each weapon*.
- Overconfidence. NVGs and laser pointers do NOT replicate daytime capabilities. A distant SBF unit will have difficulty maintaining situation awareness, difficulty seeing and communicating with the maneuver element, and difficulty controlling the fire of each weapon in the dark.

7. Direct maneuver with a Hand-held Laser Pointer

Procedure. 'Snake' the objective, key terrain, and control measures, if necessary, to orient your unit. 'Snake' the unit's destination. Point the IR beam at your feet or an offset start point, and then run it along the route that you want the unit to follow. Issue directions as you point out the route.

Techniques

- When marking many different features, use slow IR beam movements and talk through each laser direction.
- Small unit leaders can mount their Hand-held Laser Pointer to the top of their NVGs with tape for hands-free access.
- When communicating by radio, use slow IR beam movements and clear explanations. Confirm each mark. The firing unit may be able to confirm targets by responding with their own laser mark.

Common Errors. Overconfidence. Each observer sees your laser marks from a different direction. Some marks are not visible at all. Movement orders may easily be misunderstood.

Section 2.5

Laser Designators

PEQ-1A SOFLAM

PEQ-1A Data Sheet
PEQ-1A Training Handout

PVS-13

PVS-13 Data Sheet
PVS-13 Training Handout

How to Boresight PVS-13 to PEQ-1A

PEQ-1A SOFLAM / PVS-13 Tactics, Techniques and Procedures

PAQ-3 MULE (*TBD*)

PAQ-3 MULE Data Sheet (*TBD*)
PAQ-3 MULE Training Handout (*TBD*)
PAQ-3 MULE Tactics, Techniques and Procedures (*TBD*)

PEQ-1A SOFLAM

1. Nomenclature: AN/PEQ-1A Special Operations Forces Laser Marker (SOFLAM)

2. NSN: 7H-5860-01-408-7242

3. Manual: SW230-AD-MMO-010

4. Description:

The PEQ-1A SOFLAM is a man portable laser designator used to mark targets for laser-guided ordnance and a laser range finder for determining the distance to a target.

5. Characteristics:

Weight of Laser Marker: 12.0 lbs

Weight of System: 17.8 lbs

Range: > 5 km

Magnification: 10X

Battery: (5) BA 5590/U Lithium or (4) BB 590 NiCad

Laser Class: 4
Wavelength: 1064 nm
Output: >80 mJ

6. Accessories:

Tripod: 00-1054-9042
Night Vision Scope: PVS-13

7. Limitations:

8. Usage Notes: Currently issued only to Marine Corps reconnaissance units.

9. Supplier: Marine Corps Issue. TAMCN: E1029

PEQ-1A Training Handout

1. PEQ-1A SOFLAM

PEQ-1A is a man-portable laser designator used to mark targets for laser-guided ordnance and a laser range finder for determining the distance to a target.

2. Major components and their purposes

PEQ-1A SOFLAM Laser designator and range finder unit

Tripod

10' Remote Cable for remote operation

150' Remote Cable for remote operation

Power Cable connects PEQ-1A SOFLAM to Battery Bag

Cleaning Compound and **Lens Tissue** to clean lens

Operator's Manual SW 230-AD-MMO-010

Field Carry Case for carrying PEQ-1A in the field

Shipping Container for shipping and storage

Battery Bag holds five BA 5590 batteries

Vehicular Cable Adapter to power PEQ-1A SOFLAM from a vehicle

3. Battery Installation.

Set up tripod. Attach PEQ-1A SOFLAM to tripod. Insert batteries in Battery Bag. Connect Battery Bag to PEQ-1A SOFLAM using the power cable.

4. Controls

OFF/RANGE/MARK/OR switch turns PEQ-1A on. Turn to RANGE for rangefinding or MARK for laser marking.

PRF Code Buttons select the Pulse Repetition Frequency.

Eyeiece Diopter Ring focuses the eyepiece.

RETICLE switch. Pull to illuminate reticle. Turn clockwise to brighten. Push off.

FIRE pushbutton. In RANGE mode, fires laser once. In MARK mode, fires laser continuously.

FIRST/LAST/TEST switch is used to discriminate between two targets along the same line of sight. TEST position illuminates all indicators in the Eyepiece Display Screen.

Eyepiece Display Screen

- XMT illuminates when laser is transmitting.
- HOT illuminates when laser is overheating.
- MLT illuminates when multiple targets have been detected.
- BAT illuminates when power source is low.
- The four-digit range indicator display the target range in meters when the FIRE pushbutton is pressed.

5. Rangefinding Operation

Remove lens cap and eyeshield plug.

Set OFF/RANGE/MARK switch to RANGE/MARK or O/R.

Enter the PRF code.

Set FIRST/LAST/TEST switch to FIRST.

PVS-13

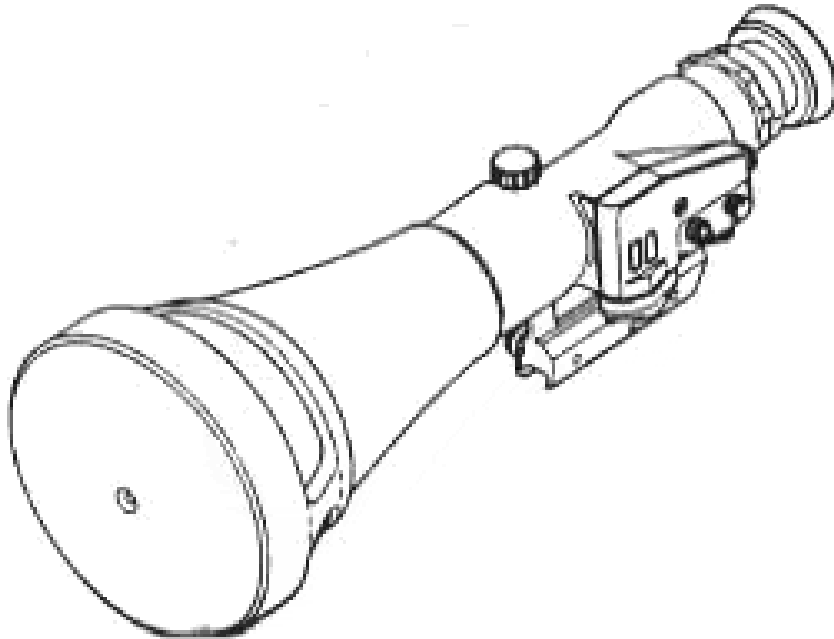

1. Nomenclature: AN/PVS-13 Laser Marker Night Vision Sight (LMNVS)

2. NSN: 7H-5855-01-407-2300

3. Manual:

SW215-AW-MMO-01A *Operator's and Maintenance Manual for AN/PVS-13, Laser Marker Night Vision Sight (LMNVS)*

4. Description:

The PVS-13 LMNVS provides night operation capability to the PEQ-1A SOFLAM. The PVS-13 is capable of viewing the beam of laser pointers.

5. Characteristics:

Weight: 4.2 lbs

Range: 50 meters to infinity

System Magnification: 6X

Battery: (2) AA

6. Accessories:

Bright Light Filter: 39102755

Day Light Filter: 39102752

7. Limitations:

Maximum Altitude: 45000 ft

Water Immersion: 3 m

8. Usage Notes: The PVS-13 is issued for use only with the PEQ-1A SOFLAM.

9. Supplier: Marine Corps Issue. **VARO, Inc.** Contract No. N00164-94-C-0223.

PVS-13 Training Handout

1. PVS-13

PVS-13 provides high performance observation, target acquisition and laser energy detection during both day and night operations. The PVS-13 can focus on targets from 50 meters to infinity. The PVS-13 can view laser pointers, but not the PEQ-1A SOFLAM laser mark.

2. Major components and their purposes

Shipping Case storage container

High Light Filter used for dawn, dusk, full moon or urban lighting

Day Light Filter used during daylight

PVS-13 Night Vision Scope

Lens Tissue to clean lens

Operator's Manual SW 215-AW-MMO-101

3. Battery Installation

Insure that PVS-13 is OFF. Remove battery cap. Insert (2) AA batteries as indicated on battery housing. Close battery cap.

4. Controls

Eyepiece Focus Ring focuses eyepiece for sharpest view of reticle.

Objective Focus Knob focuses objective lens for sharpest view of scene.

Reticle Windage Knob moves reticle right or left for windage.

ON-OFF Switch turns PVS-13 ON.

Reticle Elevation Knob moves reticle up or down for elevation.

Reticle Brightness Knob adjusts the brightness of the reticle pattern.

5. Operation

Place Day Light Filter over lens when operating during the day. Turn ON. Select target. Adjust

Objective Focus Knob first. Adjust Eyepiece Focus Ring second.

How to Boresight PVS-13 to PEQ-1A

1. Boresight

Boresight the PVS-13 to the PEQ-1A during dusk or daylight. After boresighting, **DO NOT REMOVE** the PVS-13 from the PEQ-1A SOFLAM.

Insert batteries.

Loosen the two thumbscrews on the PVS-13 mount.

Mount the PVS-13 to the weaver type mounting rail on the PEQ-1A SOFLAM.

Hand tighten the two PVS-13 thumbscrews.

Turn the PVS-13 ON.

Focus the PVS-13 using the Eyepiece Focus Ring and Objective Focus Knob.

Adjust the reticle brightness with the Reticle Brightness Knob.

Adjust PVS-13 reticle using the Reticle Windage and Reticle Elevation Knobs until the target in the PVS-13 reticle *coincides* with the target in the PEQ-1A SOFLAM reticle.

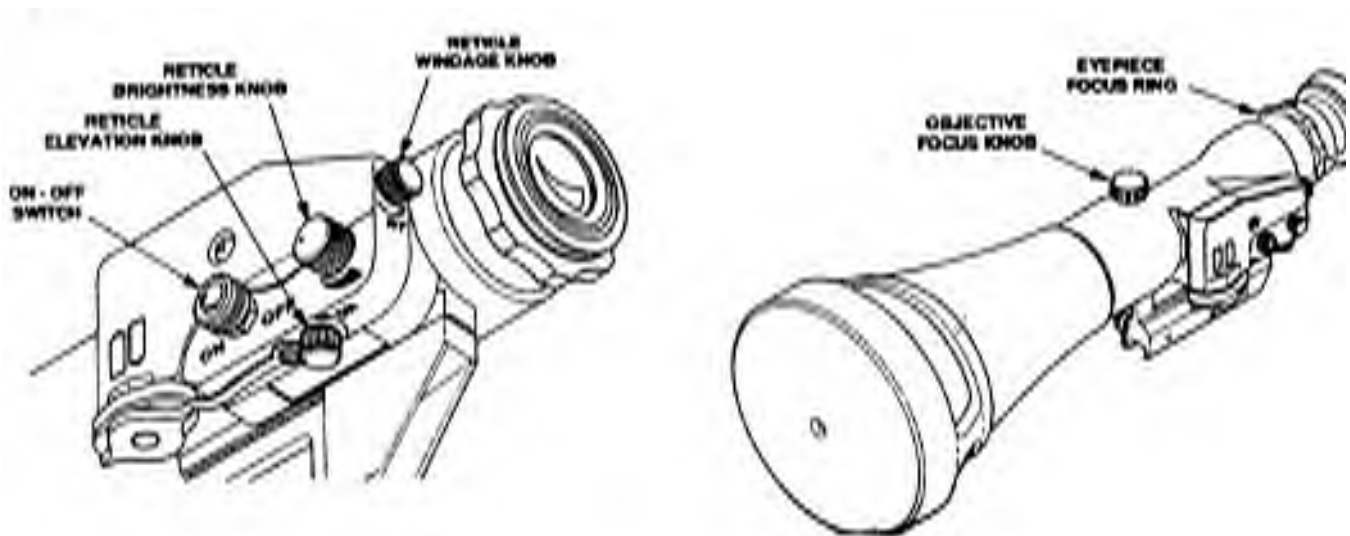

PEQ-1A SOFLAM / PVS-13 TTP

1. Remote fire the PEQ-1A in the dark

Procedure. Set up PEQ-1A SOFLAM. During daylight or dusk Boresight PVS-13 to PEQ-1A SOFLAM. Attach either 10 foot or 150 foot remote operating cable. Select target as if planning to fire: enter PRF code and adjust FIRST / LAST / TEST switch. Move to remote location. Establish comm with aircraft. When needed, fire PEQ-1A with remote switch.

Techniques

- PEQ-1A does NOT need to be level to be boresighted or fired.
- PEQ-1A does NOT need to be mounted on the tripod. Any solid surface that keeps the PEQ-1A steady, and allows access to the controls will do.

Common Errors

- Not locking tripod. Any movement of PEQ-1A will affect aim.
- Not removing laser cover.
- Not boresighting.

2. Create range sketch with PEQ-1A

Procedure

Techniques

Common Errors

Section 2.6

IR Signals

IR Signals

Phoenix Beacon Data Sheet
Phoenix Junior Data Sheet
Firefly Data Sheet
IR Chemlites Data Sheet

IR Signals Tactics, Techniques and Procedures

Phoenix Beacon

1. Nomenclature: Phoenix Beacon

2. NSN: 5855-01-396-8734

3. Manual: NONE

4. Description:

The Phoenix Beacon is a pocket-sized, waterproof, programmable IR beacon. It emits a user-programmable code that can be seen with NVGs up to 32k away.

5. Characteristics:

Weight: 2 oz (with battery)
Battery: (1) 9-volt or (1) BA-3090
Battery Life: 5 to 320 hours (varies with code length)
Memory: 20 seconds
Size: 1" x 0.75" x 2.5" (with battery)
Wavelength: 880 nm
Intensity: 750 mCd

6. Accessories: NONE

7. Limitations:

Easily lost. No dummy cord eyelet. Can be seen through clothing. Can be seen by enemy with NVGs.

8. Usage Notes:

With a coin or dogtag, the user taps a code into the 20-second memory. Beacon can be used to mark static positions, SBF positions, moving units, linkup points, vehicles, LZ-ITG, and CAS-FAC positions.

Can be re-programmed in the field.

9. Supplier:

Night Vision Equipment Corporation, Inc., P.O. Box 266, Emmaus, PA 18049-0266, POC: Gene Adcock, VP, (610) 391-9101, FAX (610) 391-9220, <http://www.nvec-night-vision.com>, nvec@ptdprolog.net, Phoenix Beacon, Model IR-15, \$65.00, Two-channel Phoenix 2.5 (5855-01-451-9877) IR-25, \$129.00

Phoenix Junior

1. Nomenclature: Phoenix Junior

2. NSN: 5855-01-438-4588

3. Manual: NONE

4. Description:

The Phoenix Junior is a pocket-sized, waterproof IR beacon that emits a constant 45 flashes per minute. It was designed to replace the standard DoD Budd-Light flashing IR beacon.

5. Characteristics:

Weight: 2 oz (with battery)

Battery: (1) 9-volt or (1) BA-3090

Battery Life: 10 hours

Diode Life: 20 hours

Flash Rate: 45 ppm

Size: 1" x 0.75" x 2.5" (with battery)

Wavelength: 830 nm

Intensity: 750 mCd

6. Accessories: NONE

7. Limitations:

Not programmable. Easily lost. No dummy cord eyelet. Can be seen through clothing. Can be seen by enemy with NVGs.

8. Usage Notes:

Beacon can be used to mark static positions, SBF positions, moving units, linkup points, vehicles, LZ-ITG, and CAS-FAC positions.

9. Supplier:

Night Vision Equipment Corporation, Inc., P.O. Box 266, Emmaus, PA 18049-0266, POC: Gene Adcock, VP, (610) 391-9101, FAX (610) 391-9220, <http://www.nvec-night-vision.com>, nvec@ptdprolog.net, Phoenix Junior, Model IR-14, \$20.00

Firefly

1. Nomenclature: Firefly

2. NSN: 6240-01-275-8080

3. Manual: NONE

4. Description:

The Firefly is a pocket-sized IR beacon that emits a steady IR light that can be viewed with NVGs.

5. Characteristics:

Weight: 2 oz (with battery)

Battery: (1) 9-volt or (1) BA-3090

6. Accessories: NONE

7. Limitations:

Not programmable. Easily lost. No dummy cord eyelet. Can be seen through clothing. Can be seen by enemy with NVGs. Does not flash.

8. Usage Notes:

Beacon can be used to mark static positions, SBF positions, moving units, linkup points, vehicles, LZ-ITG, and CAS-FAC positions.

9. Supplier: Marine Corps Supply System.

IR Chemlites

1. Nomenclature: IR Chemlite

2. NSN: 6260-01-195-9752

3. Manual: NONE

4. Description:

Six-inch chemlite glows with IR light for three hours when snapped. Designed for marking equipment, locations and personnel. Visible only to Marines equipped with NVGs.

5. Characteristics:

6. Accessories: NONE

7. Limitations:

Visible to an enemy equipped with NVGs. Light expires after three hours.

8. Usage Notes:

Unlimited potential uses. Used for marking LZs, routes, linkup points, and assembly areas. Tiny IR chemlites (1 ½" 9528105) are also useful for marking individuals or map reading.

Colored Chemlites are less visible when the enemy is equipped with NVGs:

Blue NSN 6260-01-178-5560

Green NSN 6260-01-074-4229

Yellow NSN 6260-01-196-0136

Red NSN 6260-01-178-5559

White NSN 6260-01-218-5146

9. Supplier:

Marine Corps Supply System.

Omniglow Corporation, 20-C Pimentel Court, Novato, CA 94949

IR Signals TTP

1. Provide ITG at LZ

Procedure. Use radio to brief aircraft grid and ITG. Signal inbound aircraft with one method of distant ITG. Mark LZ with one method of near ITG.

Techniques.

- Each LZ needs one method of distant ITG and one method of near ITG. Although radio is the primary signal, ITG is always emplaced. The no-comm plan is to extract using ITG only.
- Distant ITG. IR beacon, preferably a programmable Phoenix, is the best distant ITG signal. A beacon can be made directional by placing it inside an M-203 or 60mm mortar fiber.

- Distant ITG. IR Hand-held Laser Pointer 'Rope,' IR chemlite 'buzzsaw,' visible chemlite 'buzzsaw,' visible light flashlight, or visible pyro are also distant ITG techniques, listed in order of preference.
- Near ITG. IR chemlite 'T' is the best near ITG. The 'T' is the landing point of the first helicopter. Helicopter lands nose into the wind, so that the 'T' is readable. Five IR chemlites, placed 7 meters apart comprise the 'T.'
- Near ITG. Visible light chemlite 'T,' is second option. Smoke, which is visible to pilots on NVGs can also be used on clear nights.

Common Errors

- White Strobe. Avoid using a white strobe. It looks like muzzle flashes to the aircraft.
- Wind 'T' with single visible light chemlites. IR chemlites are much more visible than visible light chemlites. If no IR chemlites are available, tape two colored chemlites together at each position. For pilots on NVGs, red chemlites are more visible than green chemlites.
- Unsecured chemlites. All chemlites need to be doubly secured to the deck to prevent scattering under rotor wash. Each chemlite should be staked down with a large nail, with a cord holding it to a bush or rock. Carry an ITG kit with chemlites and these additional items.

2. Mark Pickup Zone

Procedure. Use a beacon for distant ITG. Use a wind 'T' for near ITG. In a large PZ, use an IR chemlite at each staging point to guide Marines. Attach the chemlite to an MRE placard that lists the serials for each wave.

Techniques

- Use two chemlites to mark boundaries of the MACO gate. All Marines pass through the gate on their way to their serial staging point. Control and accountability is all done at the MACO gate.
- Mark aircraft windows with chemlites. One, two, or three chemlites, placed vertically or horizontally, can mark each aircraft. Crew chiefs should know what serial is expected.

Common Errors. Poor planning. Night PZs are difficult to execute. A PZ sketch, showing ITG, serial staging points, LZ control freqs, MACO gate, and serial assignments should be developed by both the ACE and GCE.

3. Mark Linkup Point

Procedure. Select a linkup point that is near a landmark. Mark the linkup point with the SOP daylight mark and the SOP night mark.

Techniques

- A programmable Phoenix Beacon is the best SOP night mark. The beacon can only be seen by Marines wearing NVGs and the code can then be confirmed by the moving unit.
- IR chemlites can be used for the night linkup point mark. Chemlites are difficult to see from a distance and difficult to see in vegetation.
- SOP linkup procedures need to be rehearsed. PVS-7 IR illuminators can be used to flash the linkup signals back and forth from the moving unit contact team to the stationary unit observers who are overwatching the linkup point.

Common Errors

- Poor choice of linkup point. Do not select a linkup point far from any landmarks. The moving unit should be able to find the linkup point by shooting an offset from a landmark.
- GPS dependence. GPS does NOT solve all linkup problems. Use the map as the primary reference, and the GPS as the backup.
- Moving the linkup point. The stationary unit must mark the linkup point briefed. Moving the linkup point because the point is found to be less than ideal confuses the moving unit.
- Hidden beacon. Place the IR beacon off the deck so it can be seen. The more vegetation, the higher the beacon must

be.

4. Mark maneuver element

Procedure. Mark both flank men of the maneuver element with IR signals. Mark the flank man closest to the SBF position with a programmable Phoenix Beacon tucked under his helmet band. Mark the far flank man with an IR chemlite under his helmet band.

Techniques

- The unit leader can be marked with an IR beacon. Flanks can be marked with additional beacons or IR chemlites.
- In certain situation, ALL Marines can be marked with IR chemlites under their helmet bands.
- The SBF position can also be marked with a programmable Phoenix beacon so adjacent units and RWCAS can differentiate between the SBF and the maneuver element.

Common Errors

- Overmarking. On an IR-cluttered battlefield, leaders need to minimize IR light to insure that only important positions and units are marked.
- Early marks. If the enemy has NVGs, all markings must remain off for as long as possible.

Section 2.7

IR Ammunition

IR Flares

IR Flares Data Sheet
IR Flares Training Handout *(TBD)*
IR Flares Tactics, Techniques and Procedures *(TBD)*

IR Para Flare *(TBD)*

IR Para Flare Data Sheet *(TBD)*
IR Para Flare Training Handout *(TBD)*
IR Para Flare Tactics, Techniques and Procedures *(TBD)*

IR Illumination Mortar Round *(TBD)*

IR Illumination Mortar Round Data Sheet *(TBD)*
IR Illumination Mortar Round Training Handout *(TBD)*
IR Illumination Mortar Round Tactics, Techniques and Procedures *(TBD)*

IR Illumination Artillery Round *(TBD)*

IR Illumination Artillery Round Data Sheet *(TBD)*
IR Illumination Artillery Round Training Handout *(TBD)*
IR Illumination Artillery Round Tactics, Techniques and Procedures *(TBD)*

IR Smoke Grenade *(TBD)*

IR Flares

1. Nomenclature:

Model MEI-101 Night Vision Signal
Model MEI-102 IR Illuminating Device
Model MEI-200 Night Illumination Kit

2. NSN: NONE

3. Manual: NONE

4. Description:

MEI-101 is a dual-purpose flare. One end emits orange smoke for daytime signaling, the other end is an IR flare for night signaling.

MEI-102 is a 30-second IR ground flare.

MEI-200 consists of a launcher and seven aerial flares. Each flare has a burn time of 4 seconds at an altitude of 400 feet.

5. Characteristics:

MEI-101 Weight: 8.5 oz

MEI-102 Weight: 10 oz

MEI-200 Weight: 8 oz

6. Accessories: NONE

7. Limitations:

The *visible* signature of each device is comparable to a burning match.

8. Usage Notes:

The near- and mid-infrared wavelengths emitted are highly visible to NVGs and thermal imaging devices.

9. Supplier:

Night Vision Equipment Corporation, Inc., P.O. Box 266, Emmaus, PA 18049-0266. POC: Gene Adcock, VP, (610) 391-9101, FAX (610) 391-9220, <http://www.nvec-night-vision.com>, nvec@ptdprolog.net

Section 2.8

Combat ID

Combat ID

Glo-Tape Data Sheet
Luminous Tape Data Sheet
Glint Tape Data Sheet (*TBD*)
Cold Black Data Sheet (*TBD*)

Combat ID Tactics, Techniques and Procedures

Glo-Tape

- 1. Nomenclature:** Type IFF-980 Adhesive, Type IFF-67 Sew-On.
- 2. NSN:** NONE
- 3. Manual:** NONE
- 4. Description:** Glo-Tape is a black duct-tape that reflects IR light.
- 5. Characteristics:**

Wavelength: 800 - 1200 nm
Visible Light Signature: Black Tape
IR Signature: Bright Glow

- 6. Accessories:** NONE

- 7. Limitations:**

- 8. Usage Notes:**

Glo-Tape is designed for marking vehicles and positions. When illuminated with visible light, it exhibits no reflective characteristics. When illuminated with IR light, the tape appears to glow brightly. The reflection is only seen by those with NVGs.

- 9. Supplier:**

Night Vision Equipment Corporation, Inc., P.O. Box 266, Emmaus, PA 18049-0266. POC: Gene Adcock, VP, (610) 391-9101, FAX (610) 391-9220, <http://www.nvec-night-vision.com>, nvec@ptdprolog.net

Luminous Tape

1. Nomenclature: Luminous Tape

2. NSN:

9390-00-067-6159

9390-00-282-7867 Plastic, 4" wide, Phosphorescent

9390-00-926-1363 RED ORANGE Plastic, 1.5" wide, Fluorescent

9390-01-054-1809 YELLOW Plastic, 2" wide, Fluorescent, Striped

9390-01-066-9542 RED ORANGE Plastic, 0.5" wide, Fluorescent

9390-01-071-5630

9390-01-295-8978

9390-01-363-8269 RED Plastic, 1.8" wide, Fluorescent

9390-01-363-8270 WHITE Plastic, 1.8" wide, Fluorescent

9390-01-468-9906 Elastic Helmet Band with luminous tags.

3. Manual: NONE

4. Description:

Luminous tape is designed to reflect white light, making it visible in the dark. Phosphorescent tape absorbs white light and then glows in the dark.

5. Characteristics:

Multiple types and sizes of luminous and phosphorescent tape exist in the Marine Corps Supply System. Commercial luminous tape is also available.

6. Accessories: TBD

7. Limitations: TBD

8. Usage Notes: Unit SOPs should address use of luminous tape for combat ID purposes.

9. Supplier: Marine Corps Supply System.

Combat ID TTP

1. Mark individual Marines

Procedure. Unit SOP should define individual Marine markings. Each man can be marked in a number of ways, depending on his billet and the unit's mission.

Techniques

- Cat eyes on helmet band. All Marines should be issued helmet bands, even when cammie nets are worn. Helmet band can hold IR chemlites, IR beacons, as well as natural camouflage.
- Cat eyes sewn to outside of soft cover. Alternatively, cat eyes can be sewn inside the soft cover so that the luminous tape is only visible when the band is folded back.
- For a night raid, each element can be marked differently. Each unit symbol consists of two strips of luminous tape, ¾" x 1 ½". The support element is two horizontal stripes, the assault element is two vertical stripes, the security element is a cross and the command element is a 'T'. In addition, two nickel-sized dots mark element leaders, usually platoon commanders and platoon sergeants. One nickel-sized dot marks a squad leader.
- 1" Glint Tape square on top of helmet allows aircraft, especially RWCAS, to see each Marine.
- 1" x 3" strip of Glint Tape on left rear shoulder allows aircraft, especially RWCAS, to see each Marine. Additionally, maneuver elements can be seen by SBF units.
- For helicopter extract, each stick leader can be marked with an IR chemlite.

Common Errors. Too few marks make coordination difficult. Key leaders, and key positions should be easily identified. Too many marks are confusing and counterproductive.

2. Mark vehicles and equipment

Procedure. Mark vehicles with two 3" squares of Glint tape on the front corners of the hood for recognition from the air.

Techniques

- Doors or sides of vehicles can be marked with IR reflective tape for ground identification.
- DARPA Light, an IR flashing beacon, can be mounted to the antenna mount in the rear corner of a HMMWV for air recognition.
- An IR chemlite attached to the antenna allows vehicles to be seen from a distance.
- Unit SOP markings identifying specific vehicles and equipment can also be done.

Common Errors

Section 2.9

Accessories

Laser Boresight System

Laser Boresight System Data Sheet
Laser Boresight System Training Handout *(TBD)*
Laser Boresight System Tactics, Techniques and Procedures *(TBD)*

Flashlights

Visible Light Illuminator Data Sheet
Maxibeam Floodlight Data Sheet *(TBD)*
Finger Light
IR Flashlight Filters
Flashlight Tactics, Techniques and Procedures

IR Barriers *(TBD)*

Ghost Infrared Cloaking Fabric *(TBD)*
Medical Blanket *(TBD)*
Emergency Blanket *(TBD)*
IR Barriers Tactics, Techniques and Procedures *(TBD)*

Laser Boresight System

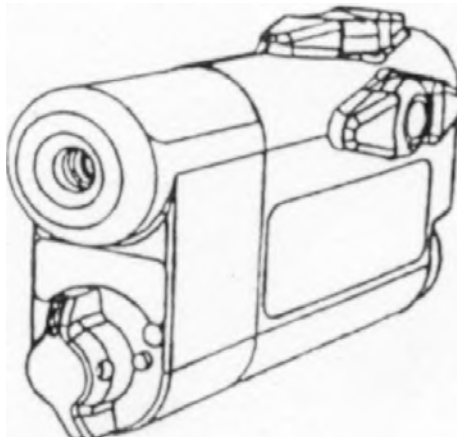

- 1. Nomenclature:** Laser Boresight System (LBS)
- 2. NSN:** 5860-01-466-2087
- 3. Manual:** Draft 12&P Manual

4. Description:

The LBS enables Marines to quickly and accurately boresight weapons sights such as iron sights, image intensifier night vision sights, laser aiming devices, and thermal weapons sights without having to fire the weapon.

5. Characteristics:

Weight of Assembly: 9.25 oz

Weight of System: 2.5 lbs

Laser Class: 2

Wavelength: 650 nm

Battery: (1) AA

6. Accessories:

Bore shaft mandrels for 5.56, 7.62 and .50 caliber weapons, carrying bag, and boresight targets.

7. Limitations: TBD

8. Usage Notes:

The LBS allows Marines to boresight weapons accessories aboard ship, aboard transport aircraft, and in assembly areas. Units on the battlefield can exchange weapons and sights based on new mission requirements and then rapidly boresight these new accessories.

9. Supplier: Marine Corps Issue FY01. TAMCN: E0956 VII BP. \$215.00

Visible Light Illuminator

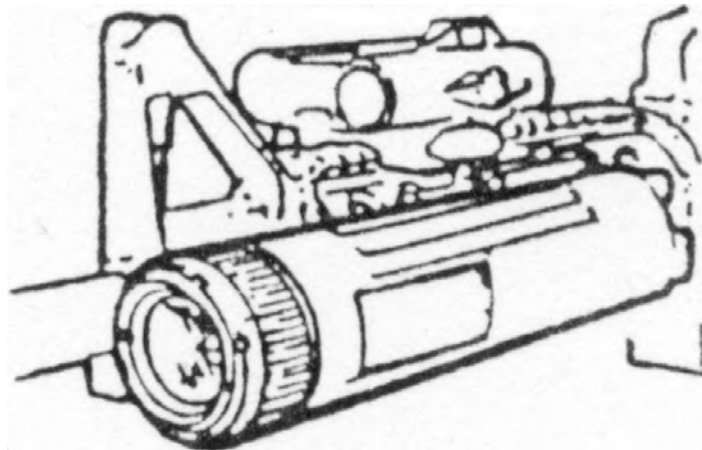

1. Nomenclature: VLI-001 Illuminator, Light, Visible

2. NSN: 5855-01-448-5464

3. Manual: *VLI-001 Technical Manual*

4. Description:

The VLI is a compact, durable, lightweight, white light weapons flashlight that mounts to the M-16A2 rifle via an integral MIL-STD-1913 rail attachment. It projects a wide-angle beam of white light for searching and target acquisition.

5. Characteristics:

Weight of Assembly: 7.19 oz
Battery: (6) AA or (3) DL123A

6. Accessories: Removable flip-up filters: red filter attachment, IR filter attachment.

7. Limitations: TBD

8. Usage Notes:

The VLI mounts to the left side of the rifle without interfering with the mounts for the PAQ-4C or PEQ-2A. On / Off switch can be activated while maintaining weapons posture and hand-weld. It can also be used in the hand-held mode.

9. Supplier: Marine Corps Issue FY01. TAMCN: N6030 II EP. \$181.00

Finger Light

1. Nomenclature: Finger Light

2. NSN: NONE

3. Manual: TBD

4. Description:

The Finger Light attaches to the finger and is designed to provide the illumination needed to read a map.

5. Characteristics:

6. Accessories: TBD

7. Limitations: TBD

8. Usage Notes:

9. Supplier:

Seitz Scientific, P.O. Box 1584, Enterprise, AL 36331-1584, (800) 347-9713, Model FL-5, \$30.00

IR Flashlight Filters

1. Nomenclature:

Model IR-1 is 1 3/4" diameter for angle-head flashlight. Model IR-1A is 1" diameter for Mini-Mag flashlight. (14) additional IR filters, for most flashlight models, are available.

2. NSN:

IR-1: 6230-01-395-9186

IR-1A3: 6230-01-395-9181

3. Manual: NONE

4. Description:

IR filters allow only IR light through, making a white light flashlight into an IR illuminator. Compared to devices designed to emit only IR light, an IR filter on a flashlight is a weak and inefficient IR light source.

5. Characteristics:

6. Accessories: Filter adapters for different models of flashlights.

7. Limitations: The flashlight's range and power is significantly reduced with an IR filter.

8. Usage Notes:

9. Supplier:

Night Vision Equipment Corporation, Inc., P.O. Box 266, Emmaus, PA 18049-0266, POC: Gene Adcock, VP, (610) 391-9101, FAX (610) 391-9220, <http://www.nvec-night-vision.com>, nvec@ptdprolog.net

Flashlight TTP

1. Clear a room. Clear a building.

Procedure. Use white-light flashlights mounted on weapons.

Techniques

- Flip-up NVGs and turn on white light upon entering the building.
- White light provides better visibility, quicker response, and better target ID. White light allows a wider field of vision

in the restricted MOUT environment. Human eyes using white light cannot be dazzled by pyro, detonations, muzzle flashes, or cultural lighting like NVG wearers can.

- Casualties and EPWs can be handled better under white light.
- Non-combatants can be identified and briefed better under white light.

Common Errors. Using IR light. Without starlight or moonlight, NVGs work poorly indoors. To use IR light, all Marines must have NVGs. Mixed units, some with NVGs, and some without, are dangerous. IR pointers and illuminators provide good visibility indoors, but NVG wearers can be dazzled by lighting and enemy actions.

2. Search detainees, bodies, and EPWs

Procedure. Use white-light flashlights mounted on weapons, if possible.

Techniques

- Always conduct a two-man search. For EPWs and bodies, one man holds his rifle at the head while the other searches. White light allows papers and equipment to be quickly identified. Detainees and EPWs are easier to deal with under white light.
- In open areas, move detainees and EPWs, indoors or behind shelter, if possible. Otherwise, limit light, use red or blue filtered light, or use IR.
- In ambush kill zones, use minimum white light to search bodies for intelligence. When using multiple search teams, mark bodies as 'searched' by crossing arms and legs.

Common Errors. Using IR light.

3. Treat a casualty. See TTP 2, above.

4. Fastrope

Procedure. Tie a lighted flashlight to the end of the rope. Throw rope to the deck.

Techniques. Crew chief can then observe rope on the deck, estimate angle of rope, length of rope and height of bird, as well as see obstacles on the deck.

Common Errors

5. Designate targets with red-light laser. See also *Hand-held Laser Pointer TTP*.

Procedure. Using a red-light laser, commonly used for presentations, communicate by marking targets and terrain.

Techniques

- Although enemy can clearly see red-light lasers, units without 100% NVGs can use a laser pointer to orient forces, direct movement, mark targets, and control fires.
- In civil disturbance and crowd control situations, key leaders can be marked with red-light lasers for snatch teams. Seeing an instigator marked with red light may cause many people in the crowd to shy away, especially if they believe that they are under the threat of precision weapons.

Common Errors

Chapter 3

Unaided Night Skills Training for Individuals

Section 3.1

Unaided Night Weapons Skills TTP

1. Fire weapons at night

Procedure. Establish and mark sectors of fire during the day. Mark the direction of principle targets during the day. Without NVGs, fire tracers to adjust effects of fire.

Techniques

- Use short bursts to minimize muzzle flash and maintain night vision. Keep one eye closed.
- Fire low. Marines tend to fire high in the dark. Use 1 in 4 tracers.
- Under illumination, keep one eye shut to maintain night vision.
- Train to execute magazine change drill and immediate action drill in the dark.
- Do not allow crew-served weapons to fire at infiltrators and give away their positions.

Common Errors. Weapons not in Condition One. Chambering a round CANNOT be done silently.

2. Throw grenades at night

Procedure. Establish and mark sectors of fire during the day. Use rocks to mark dead ground targets. Use stakes to mark location of blocking trees.

Techniques

- Avoid throwing grenades at trees, because they can bounce back at you.
- Use grenades on enemy infiltrators to avoid giving away positions.
- Unit night attack SOP should address use of grenades in the attack. In the attack, grenades can be more deadly to the attacking force and are usually NOT recommended.

Common Errors

- Straightening the pins is dangerous and should be avoided.
- Staging grenades separately from deuce gear. Train to retrieve grenades from deuce gear. Staged grenades can get muddy and wet during the night, can be hard to find, and cannot be easily retrieved when moving out in the dark.

Section 3.2

Unaided Night Field Skills TTP

"Darkness is a friend to the skilled infantryman."

- B.H. Liddell Hart, 1944

There are hundreds of field skills that infantrymen need to operate at night. Leaders need to train their Marines to operate with or without night vision equipment. The following eight skill areas contain some of these techniques.

See

1. See at night without NVGs

Procedure. Acquire night vision. Scan in alternating directions using a box pattern. Focus around objects to detect edges. Learn restrictions on night vision and cues for improving night vision.

Techniques

- Acquire night vision. For maximum dark adaptation, expose eyes to 30 to 45 minutes of darkness. Exposure to bright light after this requires 5 to 45 minutes to regain night vision.
- *Always* adapt to the dark, even if NVGs are going to be used. When NVGs are then removed, night vision is regained in 2 minutes. If night vision was never acquired, *another* 30 to 45 minutes is needed.
- Do not wear the poncho hood. It reduces field of view.
- Use binoculars. In moonlight, your eyes can spot a man at 240 meters, or 700 meters with binoculars.
- Scan continuously. Scan from left to right, then right to left, using a slow, regular, box-shaped scanning movement. Avoid looking at an object directly. Look 10 degrees off-center to see outlines.
- Do not use lights or illumination. If light must be used, red filtered light allows you to retain night vision. Blue light is more difficult for the enemy to see, but does NOT allow you to retain night vision.
- Avoid losing night vision. Close eyes against lightning, flares, headlight, or other lights. If only one eye can be closed, that eye will maintain night vision because it occurs independently in each eye.
- Know that darkness affects visual acuity and distorts human vision. Darkness modifies outlines, shapes, and colors. Visual sharpness is one-seventh of what it is during the day. Shrubs look like soldiers, fences look like enemy patrols, and a village may look like a forest.
- Know that darkness affects depth perception. Height and distance are modified. Dark objects appear farther away, light objects appear closer. Experience can *increase* an observer's ability to perceive depth. On a clear night, you can recognize land relief up to 400 meters. At ranges less than 800 meters, Marines tend to *underestimate* range by as much as 25 percent.
- Know that haze, smoke and fog limit night observation. Overcast clouds limit night observation. High humidity limits night observation.

Common Errors

- Fatigue. A tired set of eyes cannot see well. A tired observer is not mentally alert. Rotate observation duty, with or without NVGs, every 30 minutes.
- Sleep deprivation. Sleep is needed for night observation: 5 hours per day minimum, 6 to 8 hours per day for long-term operations. Even 10 minutes of sleep can restore energy. Good physical fitness and stamina allows a Marine to recover quicker.
- Poor nutrition. Lack of vitamin 'A,' normally provided by eggs, cheese and carrots, reduces night vision. U.S. forces, with good nutrition, have the best potential night vision.
- Smoking or chewing tobacco. Tobacco constricts blood vessels in the eye, reducing night vision by up to 20 percent.
- Consuming alcohol. Alcohol within 48 hours slows the ability to acquire night vision. Alcohol impairs judgement, distance estimation, and coordination.
- Fear. Apprehension rises significantly during darkness. Excitable sentries are more likely to shoot at shadows. Depression affects night vision. Nyctophobia is an abnormal fear of night or darkness.
- Night vision medical problems. Some people have less night vision capability than others. Presbyopia, the decrease in light transmission to the retina, is common in individuals over 40 years old. Night myopia, which affects nearsighted

people, is blurred vision at night. Astigmatism is an out-of-focus condition. An ordinary cold, and the narcotic medicine used to treat it, decreases night vision.

- Loss of night vision due to bright lights or muzzle flashes and failure to close at least one eye.

Avoid being Seen

2. Camouflage self and equipment

Procedure. Camouflage COLOR and SHAPE of individual gear using cammie-paint, man-made materials, and natural foliage. Use the buddy system to check for effective camouflage.

Techniques

- Camouflage COLOR. Camouflage skin with cammie paint. Light colors on low soft points. Dark colors on bony high points. Day-old beard holds cammie paint well.
- Camouflage SHAPE. Camouflage shape of helmet, radio, weapon and other distinctive man-made objects.
- Camouflage helmet. Cover helmet with piece of cammie-netting, or knotted strips of camouflage utilities. Add natural camouflage to helmet band.
- Tape all equipment that reflects light: optics, mirrors, and brass. Tape exposed brass buckles. Tape binocular lens, allowing a slit opening for observation.
- Carry helmet band, boot bands, and rubber bands for attaching natural camouflage to equipment.
- Carry extra piece of cammie netting shroud to cover crew-served muzzles and loose equipment.
- Tape or paint buttstock and camouflage hard guards of M-16A2 and M-203. Wrap boot bands around hand guard of M-16A2 to hold natural camouflage to hand guard. Do not foul charging handle area.
- Camouflage fighting hole. Holes should show no loose dirt. Use no berm or camouflage berm. The new plastic reinforced sandbags reflect light. Cover plastic sandbags with soil or cloth.
- Run 'hard routine' light discipline: no fires, no cigarettes, no lights, and no illumination.

Common Errors

- Over-camouflaging M-16A2 and M-203. Do not camouflage sights, buttstock behind charging handle, or trigger / magazine area. Avoid camouflage that interferes with operation of weapon.
- Spoiled camouflage. Day-old leaves and branches wilt and discolor. Replace natural camouflage daily.

3. Establish poncho shade

Procedure. Spread poncho on ground. Climb under poncho, insuring that edges remain flush to deck. Turn on red-lens flashlight and check map, notes, or equipment.

Techniques

- More than one head can be inserted under poncho for meeting purposes.
- A second man should watch outside of poncho insuring that no light escapes.

Common Errors

- Overconfidence. There is no safe technique for fires, cigarettes or flashlights. Use a poncho shade only for flashlight checks of maps or equipment, and only when absolutely required. Do not cover fires.
- Noise. Unpacking, spreading, using, and repacking a poncho creates unwanted noise.

4. Execute an individual infiltration

Procedure. Acquire night vision. Camouflage self and equipment. From observation point, select general route based on covered micro terrain and vegetation. Infiltrate slowly, remain in a covered approach as long as possible. When not covered, maintain concealment as long as possible.

Techniques

- Patience is silence. Move slowly. Keep still for long periods. The human eye is most effective when detecting movement. Move so slowly that an observer has difficulty seeing any movement.
- Crawl. Stay as low as possible. Wear gloves and kneepads. Feel forward for any noisy obstructions or vegetation. Keep concealment between you and potential observers.
- React to illumination. Freeze. If you have time after hearing the ‘pop’ of an illumination flare, back up one step and quickly lay down. Close eyes to retain night vision. Close one eye if vision is needed.

Common Errors. Impatience.

5. Plan an infiltration

Procedure. Conduct a map study. Compare covered routes to potential enemy positions. Use a light-level planning calendar to determine moon direction, hours and intensity. Determine legs of route, distances, general or specific azimuths, collecting features, and catching features. Brief Marines.

Techniques

- Do not depend on concealment only. A good covered route both conceals and protects.
- Select concave slopes to avoid horizons. Avoid ridgelines. Do not silhouette yourself. Be aware of your background.
- Be conservative in selecting length of route. Infiltrating a unit at night is slow and tedious.

Common Errors. Overconfidence. Always assume you are being watched. Do not overestimate the distance you are capable of traveling.

Hear

6. Listen at night

Procedure. Stop all movement. Stop all noise. Cup both hands around back of ears. Face direction of sounds and scan head from left to right. Close eyes to focus senses on sound.

Techniques

- Do not wear the poncho hood. It reduces hearing ability.
- Do not cover ears with wool cap. Remove helmet.
- In defensive positions, use nuisance obstacles, such as wired cans with pebbles, to warn of intrusions.
- Learn normal background sounds. Note *absence* of crickets and birds.
- Listen for man-made sounds, especially metal on metal, which are distinctive in the field.

Common Errors

- Impatience.
- Wearing NVGs. The concentration required to use NVGs *reduces* hearing ability.

Avoid being Heard

7. Silence self and equipment

Procedure. Tape all noisy equipment. Tie all noisy straps. Pack equipment in functional manner so you know where everything is and can noiselessly retrieve it at night. Using the buddy system, jump up and down to check for noises. Have buddy find and secure any noisy gear.

Techniques

- Tape all loose gear to prevent objects from hitting each other and making noise. Black electricians tape or green cloth tape works well. Tape weapons sling hardware.
- Tie all loose straps to prevent objects from hitting each other and making noise.
- Wear deuce gear high and tight. Except when resting, belt should always be buckled.
- Silence dog tags by covering chain with 550 cord. Tape tags together.
- Avoid wearing the poncho. Rain hitting the poncho makes distinctive noise. Unpacking it, putting it on, and taking it off all make noise. Vegetation catching on the poncho makes noise.
- Carry canteens either full or empty. Avoid letting canteens make sloshing sounds.
- Know where your gear is and how to retrieve it silently in the dark. Minimize equipment. Use resealable bags to organize contents of pack by function.
- Turn off all watch alarms.
- Turn down radios. Clip headset to helmet. Run radios squelched. Minimize radio use. Click handset twice for 'yes' and once for 'no.'
- Insert cardboard into SAW drums to silence plastic drum sounds. Insure belt can freely fire. Remove cardboard if it gets wet.
- Do not flick weapons safety. Hold it and slowly turn or push switch.
- Run 'hard routine' noise discipline: no voices, no loose equipment.

Common Errors. Removing weapons slings completely. During some activities, like evacuating wounded, fastroping, or crossing a stream, you need a sling.

8. Walk silently at night

Procedure. Silence self and equipment. Walk slowly, avoiding all ground cover that makes noise. Use equipment carefully to minimize noise. Rest often.

Techniques

- Practice walking to avoid rocks, twigs, grass, leaves, and vines.
- Use your feet to feel the ground. Keep weight on back foot as front foot gently finds new spot. Use front foot to gently feel and avoid any noisy, dry vegetation, especially leaves and twigs.
- Walk very slowly. Rest between steps.
- Tighten socks and boots to make feet more sensitive to objects on the ground.
- Use other sounds to mask movement.
- Muffle cough in the crook of your arm. Use background noises to muffle cough or clear throat.
- Move in the rain. Noise is minimized, ground is soft, and the enemy has difficulty hearing. All scents are washed away. The tradeoff, however, is that your own ability to see, hear, or smell is also gone.

Common Errors

- Fatigue. Tired Marines are noisy at night.
- Speed. Walking rapidly cannot be done silently unless on a clear, damp trail. Even then, equipment noises usually increase.

Smell

9. Smell the enemy

Procedure. Stop. Close eyes to focus senses on smell. Lift nose and smell in all directions.

Techniques

- Teach yourself the smells of the environment. Smell sap from recently cut tree branches. Smell soil from newly turned earth. Both of these smells can be evidence of enemy activity.
- Cigarettes can be detected 500m away downwind. Smoky fires can be detected farther still. Fish, garlic and other foods being cooked can be smelled several hundred meters away.
- Avoid smoking cigarettes and cigarette second-hand smoke. It interferes with your ability to smell.
- Soldiers can be smelled. The enemy smells different. Uniforms absorb smoke and food odors. Enemy excrement smells different due to a different diet.

Common Errors

- Ruining sense of smell prior to mission.
- Smelling yourself or your own unit. Avoid scented soap, after-shave, and newly laundered cammies. Limit use of soap, shaving cream, toothpaste, and insect repellent.
- NVGs. The concentration required to use NVGs *reduces* smelling ability.

Avoid being Smelled

10. Urinate

Procedure. Select loose earth or crevice. Dig hole with heel. Urinate into hole. Cover with earth.

Techniques

- Avoid spicy foods that impart distinctive odor to urine.
- Kneel to shorten distance to ground and minimize noise. Keep urine downhill.
- Aim at a leaf or bush to make no sound. Vegetation absorbs urine and minimizes smell.

Common Errors

- Noise. Loose earth and vegetation absorb noise.
- Rocks. Urine stains on rocks are visible and emit smell, especially under the sun.

11. Defecate

Procedure. Select a low site with good earth and good ground cover. Put tissue paper in blouse pocket. Keep weapon and equipment at arm's length. Dig a hole. Straddle the hole and squat with trousers pulled forward. Put used tissue paper in the hole. Cover hole with earth. Replace ground cover to camouflage. Wash hands.

Techniques

- Excrement is a reflection of diet. U.S. excrement smells different than the enemy's. Minimize smell by burying all excrement immediately.
- Use an antidiarrheal to avoid having to defecate. This is NOT recommended by doctors, but can be used in certain missions.
- Carrying excrement in plastic bags out of area of operations. Certain missions may require this to avoid evidence of activity.

Common Errors

- Noise. Place loose belt buckle in front trouser pocket.
- Toilet paper blowing away. Toss some soil on each piece of paper as you place it in the hole.
- Poor site selection. Wind blowing across cat holes on high ground can carry smell far downrange. Use low ground. Defecate more than 50 meters from running water.
- Not establishing a head in stationary positions. In mobile operations, individual catholes are sufficient. In static operations, however, a single head needs to be established to maintain hygiene standards and minimize smell of hundreds of catholes.
- Not washing hands. Dysentery results from unwashed hands and utensils.

12. Wash

Procedure. Dig a small hole with the heel of your boot. Wash, shave and brush teeth such that all water drains into this hole. Cover hole with earth. Replace ground cover to camouflage.

Techniques

- Use an electric razor. Noise of razor and battery requirement must be balanced against smell of soap or cream. Avoid shaving altogether on some missions.
- Run 'hard routine' odor discipline. Minimize use of soap and toothpaste. Do not carry or use after-shave, shaving cream, scented soap, or newly laundered cammies. Minimize insect repellent. The noise from slapping insects must be balanced with the smell of the insect repellent. No cigarettes, no fires.

Common Errors. Not establishing a wash area in stationary positions. In static operations a single wash area needs to be established to maintain hygiene standards and minimize smell.

13. Cook and eat

Procedure. When necessary, heat food. Use MRE heaters for MRE. Use small fires for boiling water.

Techniques. Heat tabs and MRE heaters smell. MRE Tabasco sauce smells. Fires smell and produce smoke. Limit cooking when in close proximity to the enemy.

Common Errors. Food smells. Do not eat in ambush positions or on patrol.

Sleep

14. Establish sleeping position

Procedure. Step ground to find roots or rocks. Roll isopor mat out and lie on it to test ground. Roll sleeping bag or ranger roll. Repack pack. Keep weapon and gear at arm's length, packed and ready.

Techniques

- Remove blouse and roll as pillow. Remove boots. Put boot bands and trouser pocket items in boots. Put cover over boots to keep animals out. Loosen trousers and socks. The weather and enemy determine what is worn while sleeping. Boots are worn while sleeping if the enemy is close.
- Carry a hammock. In wet terrain, a hammock allows the body to dry overnight. Sleep in dry night shirt, put wet clothes back on in the morning.
- Marines who snore should be turned on their stomachs.
- Know where your gear is and how to retrieve it silently in the dark. Minimize equipment. Use resealable bags to organize contents of pack by function.

Common Errors

- Not carrying isopor. Except for one-night missions, isopor is worth carrying for effective sleep.
- Strewing equipment around. Marines should be able to grab their gear with two hands and move out.

15. Build a poncho hooch

Procedure. Modify poncho with an 18-inch length of 550 cord at each grommet. Tie off neck of poncho with drawstrings. Tie each line to separate vegetation, creating lean-to shelter facing into the wind.

Techniques

- Three bungee cords, one carried around poncho, one carried around poncho liner, and one carried around isopor mat, are far better for poncho hooch construction.
- A second poncho should be carried as a groundsheet in rainy country or if needed for a ranger roll.
- In defensive positions, where ponchos are visible above fighting holes, hoochs should be constructed after dark and taken down before light.

Common Errors. Poor site selection. Avoid drainage areas if rain is expected.

Avoid Sleeping

16. Stand watch at night

Procedure. Wear all deuce gear. Carry weapon in Condition One. Stand or walk post. Drink coffee.

Techniques. If the tactical situation prevents standing, *kneel*, don't sit. If you sleep, you fall and wake up.

Common Errors. Not knowing the sleeping position of your relief.

Chapter 4

Night Warrior Training Plans

Section 4.1

Quarterly Training Plan

The following is an example of a company quarterly training plan focused on night training.

UNITED STATES MARINE CORPS
Echo Company
2nd Battalion, 5th Marines
Camp Pendleton, California 92055

Canc: 1 Apr 00
15 Dec 99

From: Commanding Officer
To: Distribution

Subj: ECHO COMPANY QUARTERLY TRAINING PLAN FOR SECOND QUARTER FY 00, JAN-MAR 00

Ref: (a) 2/5 Quarterly Training Plan for Second Quarter FY 00
(b) Echo Company METL, dtd 1 Jan 99
(c) Night Warrior Handbook

Encl: (1) METL Task Breakout
(2) Quarterly Outline Schedule
(3) Quarterly PME Plan

1. Purpose. To define the company quarterly training goal and the plan to meet this goal.

2. Quarterly Training Goal. By 30 Mar 00, the company will be trained on all the individual, individual leader, and squad-level collective tasks that are the prerequisites for the company to **Conduct a night attack**.

3. Echelon of Training. Individual. (7) squad-level collective tasks will be trained this quarter. No platoon-level or company-level collective tasks will be trained this quarter.

4. METL Training

- a. A single task from the company METL, **Conduct a night attack**, will drive all training. See Ref (b). This training goal supports the battalion QTP, Ref (a).
- b. Encl (1) shows the breakout of the tasks that comprise a night attack.
- c. Encl (2) shows the quarterly outline schedule. (6) company training weeks, totaling (16) training days, are allocated. Each week is assigned a training goal, training NCO, and training area or range.

d. (7) of the (15) squad collective skills listed in Encl (1) will be trained this quarter.

5. Other Training

- a. Encl (2) shows (2) non-supported company training weeks during the battalion maintenance standdown. In addition to the battalion-sponsored medical, dental and records review, the company will conduct (4) medical training blocks, (4) troop information training blocks, and (1) 2-day ISMT night firing exercise.
- b. The PME schedule is Encl (3). This plan supports the battalion QTP, Ref (a).

6. Higher Headquarters Training

- a. One rifle range detail of (37) M-16A2, (4) M-9, and (4) non-firing coaches is scheduled for Jan 6-17.
- b. NBC decon training for (8) Echo Marines will be held from 9-13 Feb. (1) day-long NBC exercise is scheduled for 17 Jan.
- c. Echo is assigned as OpFor for Regimental Exercise SEA HORSE WIND, from 15-30 March. Opportunities for night training during this exercise will be exploited.
- d. Internal Unit Schools Week is 15-19 Jan. Approximately 20 Marines will participate.

7. Tasks

- a. All Officers / All SNCOs. Read this quarterly training schedule.
- b. Platoon Commander / Platoon Sergeants. Train squad and section leaders. Insure squad and section leaders are competent trainers before they conduct individual training. Qualify each man in your unit on the NWB individual tasks. Qualify each leader on the NWL individual tasks. See Ref (c).

8. Coordinating Instructions

- a. Current battalion TEEP is number 05, dtd 22 Nov 99.
- b. Quarterly Training Plan brief for all NCOs and above is Friday, 18 Dec, at 0800 in the Regimental Instruction Facility.

P.J. McCALL

Distribution:

CO
XO
1stSgt
CoGySgt
Platoon Commanders (4)
Platoon Sergeants (4)

Copies to:

Bn CO
Bn OpsO

METL Task Breakout

Collective task standards are defined by either: MCO 3501.3C MCCRE, Company SOP, or *Night Combat for Infantry Companies (NCIC)*.

1. Company Task: **Conduct a Night Attack**

Scenario: Infiltrate by squads to attack position. Linkup. Recon Target. Plan and Rehearse. Establish SBF. Attack. Consolidate. Prepare to repel counterattack.

Conditions: Footmobile. Against a prepared defense. In Woods, Jungle or Mountains. At night. Non-illuminated. Given time for reconnaissance and preparation. Without external supporting weapons.

a. Platoon Task: **Conduct a Night Assault**

- (1) Squad Task: **Breach a Wire Obstacle** (Co SOP) (NCIC)
- (2) Squad Task: **Conduct Fire and Movement**
- (3) Squad Task: **Conduct a Night Assault** (NCIC)
- (4) Squad Task: **Assault and Clear a Trench** (Co SOP)

b. Platoon Task: **Execute SBF Mission**

- (1) MG Section Task: **Execute SBF Mission** (NCIC)
- (2) Squad Task: **Defend** (as SBF security)

c. Platoon Task: **Execute an Infiltration / Exfiltration**

- (1) Squad Task: **Execute an Infiltration / Exfiltration**
- (2) Squad Task: **Break Contact**
- (3) Squad Task: **Establish ORP**

d. Platoon Task: **Conduct a Link-Up** (2H.1.20) (Co SOP) (NCIC)

- (1) Squad Task: **Conduct a Link-Up** (2H.1.20) (Co SOP) (NCIC)
- (2) Squad Task: **Establish a Link-Up Point** (Co SOP) (NCIC)

e. Platoon Task: **Conduct Close Target Reconnaissance**

- (1) Squad Task: **Conduct reconnaissance patrol**

(2) Squad Task: **Establish Platoon PLD** (Co SOP) (NCIC)

f. Platoon Task: **Consolidate and Reorganize**

(1) Squad Task: **Establish LZ** (Co SOP) (NCIC)

(2) Squad Task: **Consolidate and Reorganize**

2. Individual Tasks. NCOs will select and train those individual tasks which their Marines need to support collective tasks. Platoon Commanders and Platoon Sergeants will select and train those individual leader tasks, especially night navigation, their leaders need to support collective tasks. The following tasks from Ref (c) are the minimum individual tasks required by the company:

a. Night Warrior Basic. Every man, including Corpsmen.

b. Night Warrior Leader. Every squad leader, section leader, and up.

Section 4.2

Night Warrior Field Training Plans

1. Each week of training should be driven by a field training plan. Field training plans define training tasks and assign trainers, OICs, RSOs, supporters, and evaluators. For individual night skills training, the following weekly field training plans are recommended:

Night Warrior Basic Training and Qualification
Night Warrior Leader Training and Qualification
Night Shooting Skills
Night Land Navigation
Night Infiltration and Linkup

2. Book II, *Night Combat for Infantry Companies*, lists field training plans for collective skills training. The following field training plan, for Night Warrior Basic Training and Qualification, is included as an example.

UNITED STATES MARINE CORPS
Echo Company
2nd Battalion, 5th Marines
Camp Pendleton, California 92055

13 Feb 00

From: Execution Officer
To: Echo Distribution

Subj: FIELD TRAINING PLAN FOR NIGHT WARRIOR BASIC TRAINING AND QUALIFICATION, FEB 22-24

Ref: (a) Night Warrior Handbook: Qualification Standards for Night Warrior Basic (NWB)

- Encl: (1) Training Schedule
(2) Bravo II Platoon sector sketch
(3) ORM Worksheet

1. Training Goals

- a. Individual training. Every man in the company, including corpsmen, will qualify on the (9) NWB ITS of Ref (a).
- b. Collective training. No collective tasks will be trained.

2. Execution

a. Concept of Training. Squad and section leaders are the primary trainers and will train all NWB individual skills. Each day is individual training time. Each night is an evaluation of that day's assigned skills. Weapons with PAQ-4C will be boresighted on Wednesday night and fired for record on Thursday night.

(1) The week prior, a Train-the-Trainer period is scheduled for Friday, 18 February. Platoon commanders will insure that squad leaders are competent to train NWB skills. NCOs should be familiar with the techniques included in Ref (b).

(2) Day 1. At 0800 on Tuesday, 22 February, the company hikes to the Bravo II training area. Platoon sectors are shown in Encl (2). Individual training tasks assigned are NWB 1,2,3 and 8. At 1800, squads run night practical application training on these skills. Evaluations start at 2100:

	1st Plat	2nd Plat	3rd Plat	
2100-2200	NWB 1	NWB 8	NWB 3	
2200-2300	NWB 2	NWB 1	NWB 8	
2300-0000	NWB 3	NWB 2	NWB 1	
0000-0100	NWB 8	NWB 3	NWB 2	

(3) Day 2. Daytime training by squad leaders on NWB tasks 6,7, and 9, as well as boresighting instructions. At 1800 evaluations and boresighting begins. The camouflage, silence and infiltration evaluation, NWB 6,7, and 9, runs for four hours per platoon. Boresighting runs on range 314A. Remedial evaluations on tasks 1,2,3, and 8 are held for Marines who did not qualify the previous night. Assault Sect is attached to 1st, Mortar Sect is attached to 2nd, and Machinegun Sect is attached to 3rd for evals.

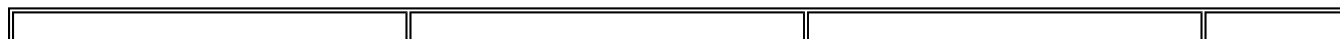

	1st Plat	2nd Plat	3
1800	Remedial	Boresight	NV
2000	Boresight	NWB 6,7,9	NV
2200	NWB 6,7,9	NWB 6,7,9	Bc
0200	NWB 6,7,9	Remedial	R

(4) Day 3. Daytime training by squad leaders on NWB tasks 4 and 5. Remedial training on tasks 1,2,3,6,7,8,9 for those Marines who have not yet passed qualification. At 1600 the entire company will move to Range 314A. At 1800, live-fire evaluations begin. Weapons sections are again attached for evals.

	1st Plat	2nd Plat	3rd Plat
1800	NWB 4,5 Live-fire	Remedial	Remedial
2000	Remedial	NWB 4,5 Live-fire	Remedial
2200	Remedial	Remedial	NWB 4,5

(5) On Friday, 25 February, the company hikes back. During the afternoon liberty formation, a Night Warrior Basic certificate will be presented to those Marines who met all the NWB qualifications.

b. Tasks

1. Lt Means. OIC of training. Conduct brief-backs with each evaluator to insure a solid evaluation plan is prepared.
2. CoGySgt. Plan and supervise all logistics support for the field exercise. Request weapons PFI NLT (6) days prior to the exercise.
3. Platoon Commanders / Platoon Sergeants. Train-the-Trainers. Supervise individual skills training. Setup and run assigned evaluation stations using Marines of your platoon. Keep accurate records of Marines who qualify at each station.

c. Coordinating Instructions

- (1) Training schedule is Encl (1).
- (2) Gear List is Co SOP.
- (3) EENT is 1810. Illum is 24%.
- (4) OIC: Lt Means, RSO: Sgt Scott, OIC R314A: SSgt Mallow, RSO R314A: SSgt DeVenichi
- (5) Evaluators:

NWB 1: 3rd Plat Lt Lawler

NWB 2: 1st Plat Lt Rapicault
NWB 3: 2nd Plat SSgt Anguiano
NWB 4: 1st Plat SSgt Mallow
NWB 5: 1st Plat SSgt Mallow
NWB 6: 2nd Plat Lt Puttroff
NWB 7: 2nd Plat SSgt Anguiano
NWB 8: Wpns Plat Lt Arroyo
NWB 9: Wpns Plat Sgt Peterson, 1st Plat Sgt Scott, 3rd Plat Sgt Keith

4. Admin and Logistics

- a. Ammunition. (40) rounds per M-16, (80) rounds per SAW.
- b. Chow. (8) MREs per man
- c. PRC-119 (8).
- d. Batteries. Spares for radios. (4) AA batteries per man.
- e. Company corpsmen, participating in all training, will be prepared to treat injuries. The R314A corpsman will not participate in training during live-fire events. Measures taken to minimize risk of injuries are shown in Encl (3).

5. Command and Signal. Co Tac will be maintained at each station. Platoons will use ISRs to run each station. Co will maintain comm with Range Control.

G.E. MEANS

Section 4.3

ISMT Field Training Plans

1. The ISMT, Indoor Simulated Marksmanship Trainer, is equipped with a night filter making it an effective tool for night weapons training. Although the M-203 and M-249 are not addressed, the nature of the combat scenarios presented by the ISMT force the squad to execute dozens of training standards in a realistic setting in a short amount of time.
2. Unit leaders should become familiar with ISMT, select a specific task to train to, and construct a training session with a small number of scenarios to focus on that task. Field Training Plans for ISMT can include crew-served weapons if the ISMT supports their use.
3. The following is an example of an ISMT Field Training Plan.

UNITED STATES MARINE CORPS
Echo Company
2nd Battalion, 5th Marines
Camp Pendleton, California 92055

From: Execution Officer
To: Echo Distribution

Subj: FIELD TRAINING PLAN FOR ISMT PLATOON WEAPONS TRAINING, MAR 28 - 29

Ref: (a) Night Warrior Handbook: Qualification Standards for Night Warrior Basic (NWB)
(b) Night Warrior Handbook: Qualification Standards for Night Warrior Leader (NWL)

Encl: (1) Trainer Notes on Boresighting and Debriefing

1. Training Goals. See Ref (a) and (b).

a. Individual training. Every man will train to the following tasks:

NWB 4. Engage targets at night with M-16A2 (or M-203), PVS-7 (or PVS-14), and PAQ-4C

b. Leader Individual training. Each squad leader will train to the following tasks using a PAQ-4C mounted to his M-16A2:

NWL 5. Mark a target at night with a Hand-held Laser Pointer

NWL 6. Control fire with a Hand-held Laser Pointer

c. Collective training. Although each squad will fight as a team, the focus will NOT be put on any squad collective tasks.

2. Execution

a. Concept of Training. Each rifle platoon has a five-hour training block. 1st at 1200 on the 28th, 2nd at 0700 on the 29, and 3rd at 1200 on the 29th. Because the ISMT can only handle one squad at a time, squads rotate on a 45-minute round-robin schedule. Each relay will fire the ISMT, rotate out for a debrief and squad leader training, and then fire a second time. Each relay uses the same ISMT weapons and PAQ-4s, but their own PVS-7 (or PVS-14). An actual M-16A2 is used by the squad leader to point his PAQ-4C at the screen.

b. Tasks. A least one trainer is required per platoon. Three trainers, the Platoon Commander, Platoon Sergeant and Platoon Guide, are ideal.

(1) OIC of Training. Coordinate with ISMT. Coordinate all support required. Brief all platoon trainers. Supervise training. Make debrief suggestions to trainers.

(2) Trainers. Brief Squad Leaders on training standards. Observe ISMT shoot. Make immediate corrections. Participate in debriefs. Note future training requirements.

(3) ISMT NCO. Brief all Marines on ISMT execution and safety. Supervise boresight. Provide scores and playback for squad debriefs.

c. Coordinating Instructions

(1) Training Schedule

1200-1210 Safety Brief - All 1st Platoon
1210-1315 Setup - OIC, Trainers, 1st Squad
1230-1315 1st Squad - First (3) Scenarios
1315-1400 2nd Squad - First (3) Scenarios
1400-1445 3rd Squad - First (3) Scenarios
1445-1530 1st Squad - Second (3) Scenarios
1530-1615 2nd Squad - Second (3) Scenarios
1615-1700 3rd Squad - Second (3) Scenarios

Following Day - All 2nd Platoon 0700-1200
Following Day - All 3rd Platoon 1200-1700

(2) ISMT Set One is ideal for night training. It consists of the following scenarios:

- (a) Combat patrol
- (b) Withdrawal through friendly lines
- (c) Linear ambush
- (d) Squad defensive position
- (e) Suppressive fire and assault on right flank
- (f) Suppressive fire fails and enemy overrun attack
- (g) Reverse slope defense

During each 45-minute shoot, two to three scenarios will be run. Each scenario is no longer than 5 minutes, which allow 10 minutes for an on-scene debrief.

(3) ISMT Set Two contains additional scenarios:

- (a) Combat patrol on recon ridge
- (b) Assault by fire on enemy bunker

(4) Equipment Needed

- (a) Each Marine: 782 Gear, Helmet, Flak.
- (b) Platoon Equipment: (12) PAQ-4C with shrouds and (12) baffles, (12) PVS-7 (or PVS-14) with head mount or helmet mount, (1) M-16A2 rifle with PAQ-4C mounted for squad leader, AA batteries for all equipment, Duct tape
- (c) Trainer Equipment: PVS-7 (or PVS-14) Training notes
- (d) ISMT facility equipment: Night filters for ISMT, (30) ISMT magazines

3. Admin and Logistics. No logistic support is required.

4. Command and Signal. No comm equipment is required.

G.E. MEANS

Trainer Notes on Boresighting and Debriefing

1. Boresighting the PAQ-4C to the ISMT. Because of the ISMT handguard construction,

brackets cannot be used to attach PAQ-4C to the ISMT weapons. Attach the (12) PAQ-4s and shrouds to each weapon with duct tape. Attach the laser baffle to each PAQ-4C. Using the first relay in the prone position, boresight each weapon using the ISMT computer boresight procedure:

- a. The ISMT boresight procedure applies only to one scenario disk at a time. If you use the rifle range sighting procedures, the PAQ-4C will only be boresighted to the rifle range disk. To use any of the combat simulation disks, the PAQ-4C must be boresighted directly to that disk.
- b. Using the boresight screen, have the Marines fire at the cross hairs and allow the computer to automatically center the shots. On the screen, using goggles, you will see two dots of light. The strong beam is the PAQ-4C, the other is the ISMT rifle laser.
- c. If, during training, you change scenario disks, the boresight must be redone.

2. Debriefing Procedures. After each scenario, the lights should be turned on and an on-screen debrief conducted.

- a. The ISMT operator can announce scores. Do NOT focus too much on scores if suppressive fire was required. If the trainer directs, the ISMT operator can play back the scene in daylight, as the trainer makes his debrief points.
- b. Individual Marines should suggest improvements to their leader's performance. A good debrief question is "How can we do this better?"
- c. Debrief notes on individual task: **NWB 5. Engage targets at night with M-16A2 (or M-203), PVS-7 (or PVS-14), and PAQ-4C (or PEQ-2A).**

1. When operating PAQ-4C, do NOT use constant beam. Do NOT interfere with Squad Leaders beam being used to signal and coordinate.
2. Discuss PVS-7 and PVS-14. Address difficulty of using head mount with helmet, especially in the prone. Helmets should be strapped.
3. Aim low. Shooters tend to fire high at night. The technique for firing with a PAQ-4C requires NO stock weld and NO sight picture. Marines should assume a good steady position with their face nowhere near the weapon. This deviation from Marine Corps marksmanship training takes some getting used to. Marines should verbally communicate, "Movement at ten o'clock, two-hundred meters!" Sights should NOT be adjusted, as they have no effect on PAQ-4C accuracy.
4. Change magazines in combat. Trainer should NOT allow same ISMT magazine to be reinserted each time. Trainer should NOT allow magazines to be staged or dropped to the deck. Practice magazine change drill: new magazine from pouch, old one in cargo pocket. "Changing!" call should alert team members. "Covering!" response should be expected. "I'm up," "Malfunction!" and unit SOP communications can also be trained.

d. Debrief notes on leader individual tasks

1. **NWL 5. Mark a target at night with a Hand-held Laser Pointer.** The PAQ-4C is used as a pointer to assign sectors and targets. The Squad leader should draw an exaggerated vertical line when defining sectors, "This dip in the treeline is your left flank!" Squad Leaders should 'snake' a target reference point, drawing a squiggly figure eight on the target, "This bare sport on the deck is TRP 3!" After assigning sectors or targets, have team leaders backbrief, using their own PAQ-4C as pointers, "Where is the right flank of your sector?"
2. **NWL 6. Control fire with a Hand-held Laser Pointer.** The squad leader needs to take charge of the situation. He needs to listen to the ISMT frag order. He should execute the order correctly, identify friendlies on screen, and open or cease fire as required. When his voice commands are

not heard, or PAQ-4C beam is not seen, he should move to team leaders to insure communications.

- a. The Squad Leader needs to enforce the four safety rules. Trainers should hear weapons go to SAFE between engagements.
 - b. The Squad Leader needs to control the weapons conditions of his squad. The four weapons conditions and their correct commands should be reinforced.
 - c. Teams cover their sectors. Random firing across the screen is poor fire discipline.
 - d. Other lessons: Rates of fire, Shoot to kill versus shoot to suppress, How to use M-16A2 as a suppressive weapon.
- e. After leaving the line, each squad leader conducts a debrief outside the ISMT. If three trainers are available, one for each squad, the trainer can also participate.

3. Additional Training Tasks. The PVS-4 scope can also be attached to ISMT weapons for training on the following task: **Engage target at night with PVS-4 (or PVS-17) on M-203 (or M-16A2).**

Chapter 5

Night Vision Equipment

Section 5.1

Night Vision Equipment Distribution Lists

1. Tables A through D are recommended equipment distributions for a Rifle Company.

Current equipment is shown as allocated by T/E N1164.

Future equipment is shown as either an 'F' or as a replacement for current equipment.

Recommended changes to current allocations are shown as an 'R.'

Equipment not allocated, but recommended for purchase, is also shown.

Alternate distributions are shown as an 'A.'

2. Weapons. M-16A2, M-203, M-249, and M-9 are shown as assigned by T/O 1013G.

3. PVS-7. (73) are assigned to riflemen, assaultmen, machinegunners, and mortar leaders.

Unlike the newer PVS-7D, PVS-7B were issued without helmet mounts. Helmet mounts, NSN 5855-01-441-0401, \$105.00, should be back-ordered for PVS-7B.

Marine Corps recommendation is for Assistant Automatic Riflemen to be issued PVS-7, insuring that every man in the rifle squad is equipped with NVGs. This recommendation however, leaves only (13) remaining for the supporting weapons sections. Tables B and C distribute PVS-7s to the weapons section. The Assistant Automatic Riflemen are currently shown as 'R,' in need of (27) additional PVS-7s.

(73) PVS-7 plus (75) PVS-14 totals (148) NVGs for the company. A T/O 1013G Rifle Company has (182) Marines. (34) more PVS-7 would equip every man.

Requirements Division should increase company PVS-7 allocation from (73) to (107).

4. PVS-14

(75) are assigned to all company leaders, rifle platoon leaders down to the fire team level, and Automatic Riflemen. None are assigned to the weapons sections.

5. 3X Magnifier

(40) are assigned to all company leaders down to the squad leader, all machinegun leaders, and each

assault team. Because the 3X Magnifier is a component of the PVS-7 or PVS-14, T/E N1164 does NOT specify how many 3X Magnifiers a company rates.

6. PAQ-4C / PEQ-2

(76) are assigned to each Rifleman, Fire Team Leader, Squad Leader, Platoon Commander, Platoon Sergeant, and Assault Section Gunner.

The Marine Corps has procured M-203 mounts for the Fire Team Leader's PAQ-4C. Each company rates (27). No boresight procedure for this mount has yet been published.

Marine Corps recommendation is for every Assistant Automatic Rifleman to be equipped with a PAQ-4C. Current issue of (76) pointers does not support this. Assistant Automatic Riflemen, currently shown as 'R' need (27) more PAQ-4C for their M-16A2s.

Automatic Riflemen, currently shown as 'R,' need (27) PAQ-4C, an M-249 mount, and a boresight procedure. This is in *addition* to the PAS-13 TWS being acquired for M-249. A PAQ-4C on the M-249 would give every man in the rifle squad a uniform capability.

Each assault Gunner mounts a PAQ-4C to his Mk153 SMAW using field expedient methods. A standard mount is needed so the PAQ-4C can be accurately boresighted.

Each ammo man of the Assault Section should attach a PAQ-4C mount to his M-16A2. When the gunner is NOT using the PAQ-4C on his Mk153 SMAW, the ammo man can immediately mount it to his M-16A2.

PEQ-2A. The Marine Corps is currently replacing PAQ-4C with PEQ-2A pointers. In hand-held mode, the PEQ-2A can illuminate and mark targets, identify lateral limits, and coordinate fires. If the Marine Corps does NOT issue hand-held pointers to infantry companies, (8) PEQ-2A should be allocated for company leaders: CO, XO, Weapons Platoon Commander, Mortar Section Leader, and machinegun squad and section leaders.

The PAQ-4C / PEQ-2A needs a MIL-STD-1913 rail mount for universal weapons mounting. A modified M-249 feed tray cover would mount PAQ-4C / PEQ-2A.

Marine Corps M-240G are being upgraded with a MIL-STD-1913 Mounting Rail feed tray cover. PAQ-4C / PEQ-2A should be able to mount to the M-240G.

(76) PAQ-4C plus (27) for Assistant Automatic Riflemen, plus (27) for Automatic Riflemen, plus (8) for company leaders, totals (138).

Requirements Division should increase PAQ-4C / PEQ-2A allocation from (76) to (138). PEQ-2A should *complement*, not replace, existing PAQ-4C.

7. PEQ-4

No PEQ-4s are allocated to the Rifle Company. Only FACs rate PEQ-4s. Company leaders, however, need a strong hand-held laser pointer, easily differentiated on a laser-cluttered battlefield, to call for CAS, direct maneuver, conduct ITG, control organic fires, and coordinate fires of non-organic supporting units such as HMG and TOWs.

At a minimum, the CO, XO, Weapons Platoon Commander, and Machinegun Section Leader need a hand held laser pointer.

If no PEQ-4 are allocated to rifle companies, (8) PEQ-2A should be allocated to company leaders for hand-held use. See paragraph 6.f., above.

8. IR Beacon

(13) are recommended for purchase. One for each autonomous unit: rifle platoons, machinegun squads, and the mortar section, and one for each key leader.

9. PAS-13 TWS

(33) are currently being procured, one per M-240G, and one per M-249.

The laser spot of a PAQ-4C / PEQ-2A CANNOT be seen by a Machinegunner looking through a PAS-13 TWS. How then does a machine gun section leader direct the fire of his section? How do these gunners see the IR beacons and signals of maneuver units?

(27) PAS-13 TWS are procured for M-249. The laser sport of a PAQ-4C / PEQ-2A CANNOT be seen by an Automatic Rifleman looking through a PAS-13 TW>. How then does a squad leader direct the fire of his (3) principle weapons? Mounting PAQ-4C / PEQ-2A to the M-249 is a better option. See paragraph 6.c. and 6.g., above.

Marine Corps M-240G are being upgraded with a MIL-STD-1913 Mounting Rail feed tray cover to permit the mounting of optics and sights, including the PAS-13 TWS.

10. PVS-4 and PVS-17

(27) are assigned, one for each fire team leader. PVS-17 will replace PVS-4. Alternatively, the assault section can use PVS-4 / PVS-17 on the Mk153 SMAW.

Scopes cannot be used for map reading, navigating, or any manual tasks. A team leader with M-203, PVS-14, and PAQ-4C is fully equipped.

(6) PVS-17 scopes should be acquired for the Mk153 SMAW.

Marine Corps M-240G are being upgraded with a MIL-STD-1913 Mounting Rail feed tray cover to permit the mounting of optics and sights, including the PVS-17.

11. Compass

(36) are assigned to all company leaders, each assault team, machinegun squad, and mortar tube. Additional requirements include one for each machine gun (6), and one for each fire team leader (27). Infantry leaders should purchase their own Silva-type compasses, realizing that commercial compasses are not illuminated and lack a mil scale.

12. Binoculars

(6) are assigned for each officer. Additional requirements include one for the machinegun section leader,

mortar section leader, and assault section leader.

13. Flashlight

Flashlights are NOT shown in Tables A through D. In MOUT, every man in the rifle squad should have a white-light flashlight mounted to one side of his weapon. The Marine Corps is currently procuring the VLI-001 weapons flashlight, fitted with a MIL-STD-1913 rail mount, and an IR filter attachment, for M-16A2.

Table A Rifle Platoon	M-16	M-203	M-249	M-9	PVS-7	PVS-14	3X	PAQ-4 PEQ-2	PEQ-4	Beacon	PAS-13	PVS-4 PVS-17
Squad Leader	1					1	1	1				
Team Leader		1				1		1				1
Auto Rifle			1			1		R			F	
Asst Auto R	1				R			R				
Rifleman	1				1			1				
Team Leader		1				1		1				1
Auto Rifle			1			1		R			F	
Asst Auto R	1				R			R				
Rifleman	1				1			1				
Team Leader		1				1		1				1
Auto Rifle			1			1		R			F	
Asst Auto R	1				R			R				
Rifleman	1				1			1				
Sqd TOTAL	7	3	3	0	3	7	1	7	0	0	3	3
(3) Squads	21	9	9	0	9	21	3	21	0	0	9	9
Plat Comdr	1					1	1	1	R	1		
Plat Sergeant	1					1	1	1				
Guide	1				1							
RO	1				1							
Plat TOTAL	25	9	9	0	11	23	5	23	0	1	9	9

CO				1		1	1	R	R	1		
XO				1		1	1	R	R	1		
1stSgt				1		1						
CoGySgt				1		1				1		
Police Sgt	1				1							
Driver	1				1							
HQ TOTAL	2	0	0	4	2	4	2	0	0	3	0	0
Wpns Comdr	1					1	1	R	R	1		
Wpns Plat Sgt	1					1	1					
TOTAL	2	0	0	0	0	2	2	0	0	1	0	0
Company												
1st Plat	25	9	9		11	23	5	23		1	9	9
2nd Plat	25	9	9		11	23	5	23		1	9	9
3rd Plat	25	9	9		11	23	5	23		1	9	9
Wpns HQ	2					2	2			1		
MG Sect	15			7	21		10			4	6	
Mortar Sect	3			7	4		4			1		
Assault Sect	7			6	13		7	7		1		
Co HQ	2			4	2	4	2			3		
Co TOTAL	104	27	27	24	73	75	40	76	0	13	33	27
T/E N1164	104	27	27	24	73	75		76	0	0	0	27

Section 5.2

Batteries

1. AA Batteries are needed for most night vision equipment.

Using AA batteries instead of military equivalents increases flexibility and availability. Commercial AA batteries with integral testers are especially useful. When purchased commercially in bulk, the unit price is generally \$0.50.

2. The Intra Squad Radio (ISR) uses (3) AA batteries. See <http://www.icomamerica.com/FRS>.

3. IR Beacons use 9-volt batteries.

When purchased commercially in bulk, the unit price is generally \$2.50.

4. Standard Battery Procedures

All batteries that are issued are recovered. Two types of batteries are recovered: Good and Bad. Collecting dead batteries is NOT a litter issue. Dead batteries recovered by the enemy are not only evidence of Marine operations, they can be used to trigger booby traps or power enemy equipment.

Every piece of battery-powered equipment is combat-ready at all times. It is up to the individual to know the battery status of his equipment. Two batteries should be issued to each man for every battery he requires.

The CoGySgt knows the company battery requirements. Using Section 5.1, Tables A through D, the Infantry Company currently needs:

- Night Vision Equipment: 502 AA Batteries
- Individual Squad Radios: 234 AA Batteries
- IR Beacons: 13 9-volt Batteries

These numbers are *doubled* when each man is issued spares. To go to war tomorrow, an infantry company needs **1472** AA Batteries.

Section 5.3

Standard Armory Procedures

1. Each piece of night vision equipment is assigned to an individual Marine.

Use Section 5.1, Tables A through D, to assign each piece of equipment using a NAVMC 10520 card. Each Marine then has two or three rifle cards, one for each piece of his equipment.

This billet-specific equipment list creates a *set* of equipment for each billet. When men switch billets, turn over *all* equipment, including weapon.

Establish SOPs for what SL-3 gear is drawn and what is not. Recommended examples:

- The PAQ-4C should be issued at the armory *without* the cloth bag, boresight diffuser, manual, or hexkey.
- PVS-7 and PVS-14 should be issued *without* the light interference filter, manual, or demist shields.
- 3X magnifiers are *always* drawn. Case is left in the armory. 3X is stored in NVG bag.

In the field, the cloth NVG bag holds *all* night vision equipment. PAQ-4C, spare batteries, 3X, IR beacons, chemlites, and other items are kept together with NVGs in one place. This 'Night Bag' should be worn on the deuce gear so packs can be left behind.

All weapons mounts should be attached at all times, even in the armory. PAQ-4C mounts maintain boresight even when weapons are stored in the armory.

2. The Infantry Company draws weapons and equipment in (90) minutes.

The CoGySgt should establish a tight round-robin schedule:

	H-Hour to H+20	H+20 to H+40	H+40 to H+60	H+60 to H+90
1st Platoon	Armory	Chow	Ammo	Co Gear
2nd Platoon	Co Gear	Armory	Chow	Ammo
3rd Platoon	Ammo	Co Gear	Armory	Chow
Wpns Platoon	Chow	Ammo	Co Gear	Armory

Company Gear is Comm, batteries, chemlites, HLZ kits, EPW kits, and any other mission-specific equipment.

All equipment should be drawn at all times. This reinforces equipment SOPs.

3. Storage

By Marine Corps order, serialized equipment such as night vision equipment needs to be secured, but it does NOT need to be stored in an armory.

Section 5.4

Acquiring Equipment

1. Table of Equipment T/E N1164

The company commander needs to know what equipment the company rates, what new equipment is becoming available, and what additional equipment and consumables are needed for training and combat.

2. Issue equipment is coordinated through the supply officer and ordnance officer.

Company commanders need a copy of T/E N1164 to be aware of what the company rates.

Company commanders coordinate with their ordnance officer for PAQ-4 mounts for the M-203, back-order helmet mounts for the PVS-7B, equipment replacement plans, and any other new equipment issues. The battalion ordnance officer coordinates these issues through the Regimental and Divisional ordnance officers.

3. The Marine Corps Supply System provides consumables and non-issue equipment.

Order non-issue equipment such as IR Firefly Beacons through the supply officer. Know the NSN and unit cost.

Know the NSN and unit cost of consumables such as chemlites, helmet bands, batteries, and Glint tape.

4. 'Open purchase' is used to acquire equipment that the Marine Corps does not stock.

Chapter 2 includes the addresses of suppliers and prices for each piece of open purchase equipment.

The supply officer purchases equipment directly from the manufacturer with the commander's approval.

5. Information on equipment can be found on the following web sites:

<http://www.usmc.mil> USMC

<http://www.matcom.usmc.mil> Marine Corps Material Command

<http://www.marcorsyscom.usmc.mil> Marine Corps Systems Command

<http://www.ala.usmc.mil> Marine Corps Logistics Base, Albany, Georgia

<http://www.mccdc.usmc.mil> Marine Corps Combat Development Command

<http://www.usmc.mil/info.nsf/info> ALMAR Messages